

Drawing repeated for reference

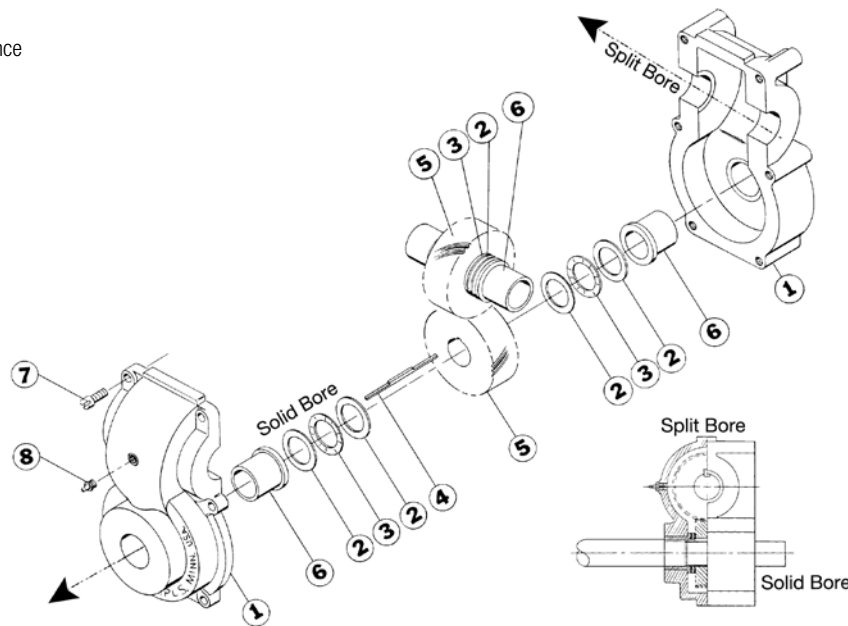

Installation

Full Length Shaft Keyway:

Keyway extends to end of shaft. In this case, it is not necessary to disassemble the Float-A-Shaft®. Without removing the plastic tubes, align the Float-A-Shaft® with the shaft on which it is to be used and gently press it on. Be sure the key is properly oriented with the keyway. The plastic tubes will fall out as the shaft extends through the unit. The plastic tubes should be saved if removal of the Float-A-Shaft® is required. Be sure the plastic tubes are inserted as the shaft is withdrawn, otherwise the internal parts will slip out of position and disassembly may be required to restore proper alignment.

Shaft Keyway Types

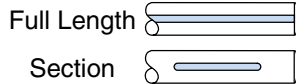

Section Keyway: Keyway does not extend to end of shaft. The Float-A-Shaft® must be disassembled for installation.

Reassembly: Reference the numbering diagram on page 1 to complete the following instructions, matching the numbers with corresponding bores.

Solid Bore Reassembly: Slide one end of the Gear Case Housing (1), which has the Flanged Bushing (6) already inserted onto the most accessible end of one shaft. Then install a Thrust Washer (2), a Thrust Bearing (3), and another Thrust Washer (2). Next, place the Key (4) in the keyway and slide the Gear (5) onto the shaft over the key. On the opposite side of the gear, place a Thrust Washer (2), a Thrust Bearing (3), and another Thrust Washer (2).

Split Bore Reassembly: Slide the following parts onto the shaft, which is positioned at a 90° angle: a Flanged Bushing (6)—Flanged end toward gear, a Thrust Washer (2), a Thrust Bearing (3), and another Thrust Washer (2). Place the Key (4) in the keyway and slide the Gear (5) onto the shaft over the key. On the opposite side of the gear, place a Thrust Washer (2), a Thrust Bearing (3), another Thrust Washer (2), and the other Flanged Bushing (6). Position this assembly

into the Gear Case Housing (1), making sure the teeth of the gears mesh. CAUTION: When trying to get the gears to mesh, rotate the gears to prevent possible damage to the teeth. Next, make sure the Flanged Bushings (6) are pushed all the way into the casting to allow maximum clearance between the gear and the bushings.

To complete the assembly, install the other half of the Gear Case Housing (1) with the Flanged Bushing (6) already inserted, and tighten the Screws (7) in the order shown here. In case of shaft binding, check for possible misalignment of the shafts or for an oversized shaft diameter.

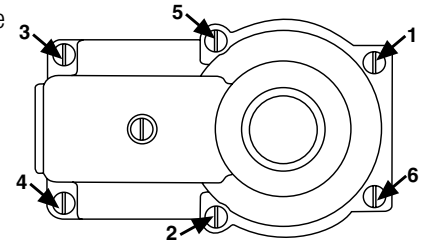

Lubrication: All Float-A-Shaft® gear boxes have been lubricated at the factory with Mobilith® SHC 460. However, units require more lubrication prior to operation. Periodic re-lubrication is also necessary for optimum performance. When re-lubricating, inject Mobilith® SHC 460 (maximum operating temperature of 300°F or higher and EP rated) into gear case, as required, via the grease zerk provided.

Mobilith® SHC 460 - 14 oz grease cartridge • P/N 0100-1605

Shaft Requirements: Shafts should be made of power transmission steel grade 4140 or better. A tolerance of **+ .000/- .002 is recommended for the shaft diameters. The shaft surfaces should be 32 RMS maximum for stationary applications, and 16 RMS maximum for traversing applications. Shaft straightness should be .0015 TIR per foot.**

Mobilith® SHC 460 is a registered trademark of Exxon Mobil Corporation, www.mobil.com
Float-A-Shaft® is a registered trademark of Tolomatic, Inc.



COMPANY WITH
QUALITY SYSTEM
CERTIFIED BY DNV GL
= ISO 9001 =

3800 County Road 116, Hamel, MN 55340 USA
http://www.Tolomatic.com • Email: Help@Tolomatic.com
Phone: (763) 478-8000 • Fax: (763) 478-8080 • Toll Free: 1-800-328-2174

© 2022 Tolomatic 202202170841

All brand and product names are trademarks or registered trademarks of their respective owners. Information in this document is believed accurate at time of printing. However, Tolomatic assumes no responsibility for its use or for any errors that may appear in this document. Tolomatic reserves the right to change the design or operation of the equipment described herein and any associated motion products without notice. Information in this document is subject to change without notice.

Visit www.tolomatic.com for the most up-to-date technical information