

LC100 RODLESS CYLINDER



LC100™ Rodless Cylinder

ABOUT THE LC100

Developed in response to customer needs for a quality, inexpensive linear actuator the LC100's simple design makes it especially affordable for applications with loads that are guided, supported and have shock absorbers or external cushions.

The LC100 provides smooth linear movement in applications such as opening & closing doors, automating factory assembly lines and solving specialty machinery problems.

The LC100 design is lightweight, space-saving and efficient with a low breakaway piston. Stroke lengths are available up to 182 inches.

APPLICATIONS

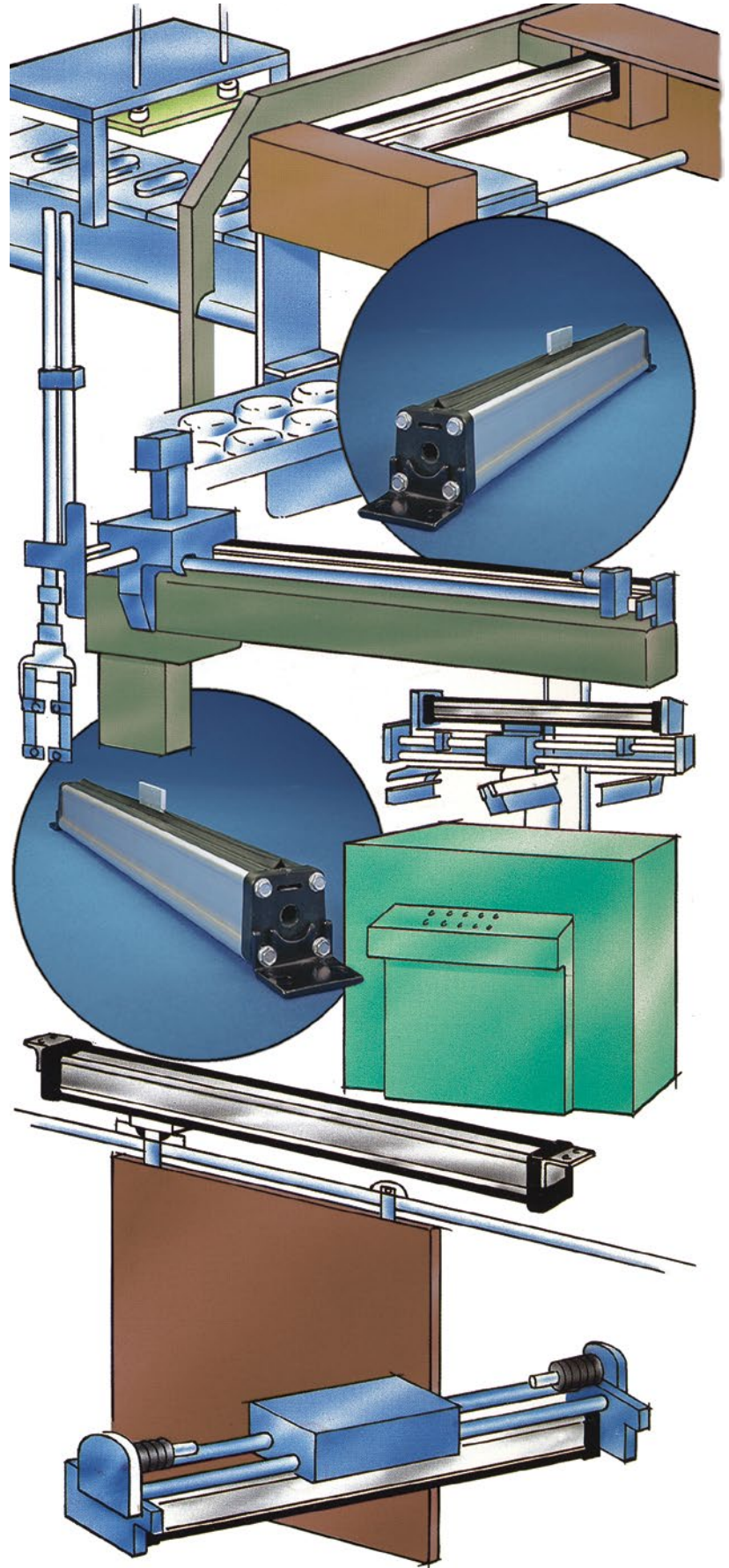

LC100 RODLESS CYLINDER

ENDURANCE TECHNOLOGYSM

Endurance Technology features are designed for maximum durability to provide extended service life.

FLEXIBLE USE

- Designed for use in three common orientations:
 - Horizontal, Piston Bracket Up
 - Horizontal, Piston Bracket Down
 - Horizontal, Piston Side Bracket

STANDARD FOOT MOUNTS

- Convenient mounting choice

THERMAL PLASTIC HEAD ASSEMBLY

- Economical yet durable material has been in service for decades

LOW BREAKAWAY

- Minimal sliding resistance allows low pressure actuation and more efficient operation

POSITIVE POSITION SEALS

- Sturdy U-cup base section assures positive positioning of seal lip for better sealing and less seal wear
- Made of custom formulated polyurethane for pliable, wear resistant seal lip

SPACE SAVING DESIGN

- Rodless cylinders can operate in 43% less space than traditional rod-style cylinders
- Simple design for worry-free performance

RIGID CLEAR-ANODIZED EXTRUDED ALUMINUM TUBE

- Lightweight, stronger, stiffer tube retains tolerance specifications when chamber is pressurized
- Keeps sealing band in place for maximized air efficiency
- Solid structural support provides durability and long life performance

! NOTE: This cylinder is designed for use in applications where the load is externally guided and supported. Some external means of deceleration and end-of-stroke positioning are required.

Tolomatic... MAXIMUM DURABILITY
EXCELLENCE IN MOTION[®]

THE TOLOMATIC DIFFERENCE

What you expect from the industry leader:



EXCELLENT CUSTOMER SERVICE & TECHNICAL SUPPORT

Our people make the difference! Expect prompt, courteous replies to all of your application and product questions.



INDUSTRY LEADING DELIVERIES

Tolomatic continues to offer the fastest delivery of standard catalog products. Modified and custom products ship weeks ahead of the competition.

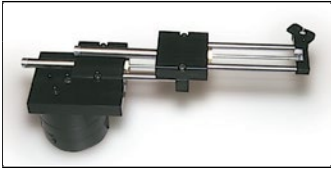

INNOVATIVE PRODUCTS

From standard catalog products... to modified products... to completely unique custom products, Tolomatic designs and builds the best solutions for your challenging applications.



ONLINE SIZING & SELECTION SOFTWARE

Online sizing that is easy to use, accurate and always up-to-date. Input your application data and the software will determine a Tolomatic electric actuator to meet your requirements.



3D MODELS & 2D DRAWINGS AVAILABLE ON THE WEB

Easy to access CAD files are available in many popular formats.

ALSO CONSIDER THESE OTHER TOLOMATIC PRODUCTS:

PNEUMATIC PRODUCTS



RODLESS CYLINDERS: Band Cylinders, Cable Cylinders, MAGNETICALLY COUPLED CYLINDERS/SLIDES; GUIDED ROD CYLINDER SLIDES

"FOLDOUT" BROCHURE #9900-9075
PRODUCTS BROCHURE #9900-4028

ELECTRIC PRODUCTS



ROD & GUIDED ROD STYLE ACTUATORS, HIGH THRUST ACTUATORS, SCREW & BELT DRIVE RODLESS ACTUATORS, MOTORS, DRIVES AND CONTROLLERS

"FOLDOUT" BROCHURE #9900-9074
PRODUCTS BROCHURE #9900-4016

POWER TRANSMISSION PRODUCTS



GEARBOXES: Float-A-Shaft®, Slide-Rite®; DISC CONE CLUTCH; CALIPER DISC BRAKES

"FOLDOUT" BROCHURE #9900-9076
PRODUCTS BROCHURE #9900-4029



3800 County Road 116 • Hamel, MN 55340 U.S.A.
Phone: (763) 478-8000 • Fax: (763) 478-8080

Toll-Free: 1-800-328-2174

Email: help@tolomatic.com • <http://www.tolomatic.com>

All brand and product names are trademarks or registered trademarks of their respective owners. Information in this document is believed accurate at time of printing. However, Tolomatic assumes no responsibility for its use or for any errors that may appear in this document. Tolomatic reserves the right to change the design or operation of the equipment described herein and any associated motion products without notice. Information in this document is subject to change without notice.

Visit www.tolomatic.com for the most up-to-date technical information

