

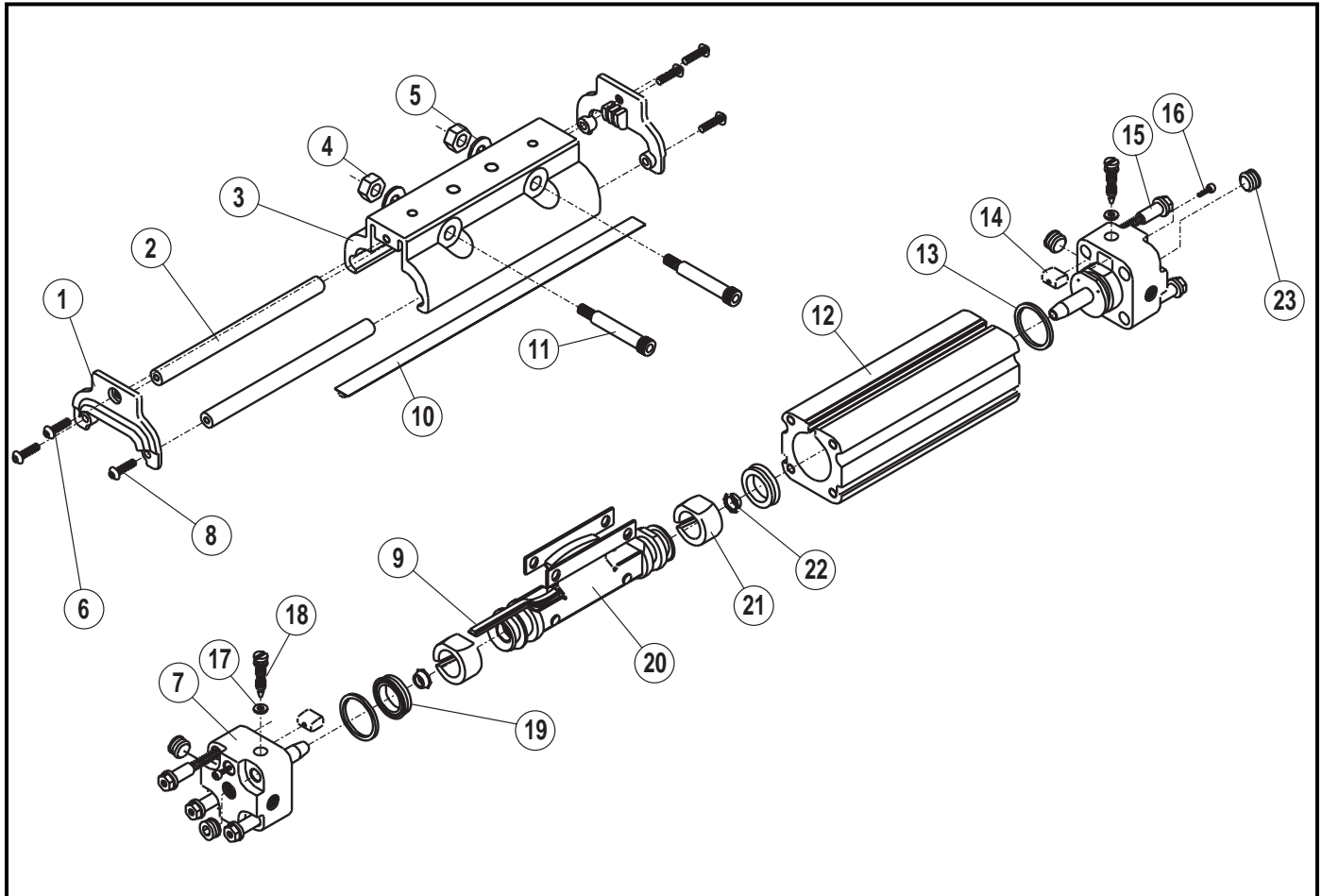

1-1/2" Band Cylinder®

BC100-150P (Multi-Ported Head) 0915-0002

**Discontinued Product
Style or Size. Parts
Sheet is for use only
with Repair Kits**



List of Parts

ITEM	PART NO.	DESCRIPTION	QUANTITY	ITEM	PART NO.	DESCRIPTION	QUANTITY
1.*	0915-1036	Carrier End Cap	2	13.*	0915-1178	O-Ring	2
2.*	0915-1170	Bearing Rod	2	14.**	0910-1343	Band Clamp	2
3.	0915-1180	Carrier Bracket	1	15.	0512-1011	Tapped Screw	8
4.	0912-1016	Self Locking Nut	2	16.**	1301-1172	Socket Head Cap Screw	2
5.	1004-1144	Washer	2	17.*,**	0910-1178	O-Ring	2
6.	0910-1081	Button Head Screw	2	18.**	0915-1177	Cushion Needle	2
7.	0515-9021	Head Assembly (multi-port)	2	19.*	0915-1042	U-Cup	2
8.	0915-1172	Button Head Screw	4	20.	0915-9013	Piston-Bracket Sub-Assembly	1
9.*	0915-9016	Sealing Band (specify stroke)	1	21.*	0915-1110	Wear Ring	2
10.*	0915-9017	Dust Band (specify stroke)	1	22.*	0915-1184	Cushion Seal	2
11.	0915-1089	Socket Head Shoulder Screw	2	23.**	1004-1073	Pipe Plug	4
12.	0915-1174	Cylinder Tube (specify stroke)	1				

* Included in Repair Kit 0915-9033.

** Included in Head Assembly, 0515-9021.

For models manufactured prior to October 15, 1991, please consult part sheet 0910-0208.

Model BC100-150 Maintenance, Assembly and Disassembly Instructions

MAINTENANCE

1. The Band Cylinder® should be kept as clean as possible around the bands and Carrier Bracket.
2. Always use air that is adequately lubricated. Tol-O-Matic recommends that a 5 to 10 weight non-detergent, petroleum oil be used. For FDA requirements, we recommend that Multitherm® PG-1 or equivalent be used. For dry air applications, please consult Tol-O-Matic, Inc., toll free at 1-800-328-2174.

CARRIER ADJUSTMENT

The tracking tension on the Carrier Bracket may be adjusted by tightening or loosening the two screws and nuts on the bracket. To tighten or loosen the screws on the BC100 Band Cylinder models, use a 3/8" open-end wrench or socket and an Allen wrench.

CAUTION: Make certain not to overtighten the Carrier Bracket adjustment screws. It is possible to tighten them enough to keep the Carrier and Piston from moving. Tightening the Carrier Bracket directly affects the cylinder's breakaway. In other words, the tighter the adjustment the higher the breakaway.

DISASSEMBLY INSTRUCTIONS

1. REMOVE CARRIER: Remove Shoulder Bolts (11), Washers (5) and Nuts (4). Remove End Cap (1) by removing Button Head Screws (6) and (8) at each end of Carrier. Remove Bearing Rods (2).
2. REMOVE DUST BAND: Loosen Band Clamp (14) holding Band by loosening Screw (16). Carefully pull one end of Dust Band (10) from under Band Clamp. Remove Dust Band.
3. REMOVE HEADS AND PISTON BRACKET ASSEMBLY: Remove four Head Fasteners (15) to free Cylinder Heads (7). Slide Piston and Bracket Assembly (20) out one end of the Tube (12).
4. REMOVE INNER SEALING BAND: Pass a screwdriver or similar tool through the slot in the cylinder tube to dislodge the Inner Sealing Band (9) from the Tube (12). (Take care in doing this step to make certain that NO SCRATCHES ARE MADE in the tube bore or slot.) IMPORTANT NOTE: Edges of Sealing Band are SHARP— Use caution when handling to avoid injury!

ASSEMBLY INSTRUCTIONS

1. THOROUGHLY CLEAN ALL COMPONENTS: Particularly the tube bore slot and bands. THOROUGHLY LUBRICATE THE TUBE AND ALL RUBBER PARTS INCLUDING THE RUBBER ON BOTH THE INSIDE AND OUTSIDE BAND WITH MAGNALUBE®-G GREASE. NOTE: DO NOT use SAE-grade, 30-weight or detergent oil.

2. INSERT NEW INNER SEALING BAND: Insert Sealing Band (9) into the cylinder tube (with the rubber portion facing up into the slot), centering the band along its entire length.

CAUTION: The metal edges of the band are very sharp. Exercise caution to avoid injury either to yourself or the band and tube when inserting both the inner and outer bands.

3. INSERT PISTON AND BRACKET ASSEMBLY: Line up flat side of Wear Ring (21) with flat top on Piston Assembly and slide Wear Ring onto piston. Insert the Piston and Bracket Assembly (20), with Wear Ring (21), new U-Cups (19) and Cushion Seals (22) in place, into the tube, passing the Inner Sealing Band through the Piston and Bracket Assembly. Push the Piston and Bracket Assembly (20) along the cylinder tube to force the Inner Sealing Band into the sealing position.
4. TRIM AND INSTALL THE NEW TOP DUST BAND: Clean Dust Band (10). Install the new Top Dust Band (10) with the rubber sealing portion facing down into the slot and centering the band along its entire length. Using a razor blade, strip rubber of steel band flush to Machined Tube (12). With tin snips, trim both the Dust Band (10) and Sealing Band (9) to the distance longer than the tube shown below on each end.

Cylinder Size	Trim Length
1-1/2", 40 mm	.656 inches

5. INSTALL CARRIER AND ADJUST CLEARANCE: Install Carrier (3) over the Piston Bracket Assembly (20). Install Bearing Rods (2) and End Caps (1) using Button Head Cap Screws (6) and Button Head Screws (8). Use Loctite® 222 on Button Head Screws (8). Install Shoulder Bolts (11), Washers (5) and Nuts (4). Adjust clearance between the Carrier (3) and the Cylinder Tube (12) by snugly tightening the two Nuts (4) evenly to the desired tension. NOTE: "Snug" means no noticeable end play by hand. If a wrench is applied to either end, both ends will turn.
6. INSTALL THE CYLINDER HEADS: Install Heads (7) with new O-rings (13) in place and tighten the four Head Fasteners (15) to hold each end in place. NOTE: The two Bands (9) and (10) should be placed above and below the Band Clamp Wedge (14).
7. REMOVE BAND SLACK: Remove slack from Band (9) and (10) by sliding the carrier (3) to one end of the Tube (12) and tighten Screw (16) closest to the Carrier (3). Slide Carrier (3) to opposite end and tighten other Screw (16).
8. CHECK ASSEMBLY AND REMOUNT: Run the Carrier (3) back and forth along the full stroke to make certain that the cylinder is properly assembled before applying air. Remount the cylinder on the machinery it was taken from.

Loctite® is a registered trademark of the Loctite Corporation, www.loctite.com
Magnalube®-G is a registered trademark of the Carleton-Stuart Corporation, www.magnalube-g.com



TOL-O-MATIC, INC.

3800 County Road 116, Hamel, MN 55340
<http://www.Tolomatic.com> • Email: Help@Tolomatic.com
 Phone: (763) 478-8000 • Fax: (763) 478-8080 • Toll Free: 1-800-328-2174



Information furnished is believed to be accurate and reliable. However, Tol-O-Matic assumes no responsibility for its use or for any errors that may appear in this document. Tol-O-Matic reserves the right to change the design or operation of the equipment described herein and any associated motion products without notice. Information in this document is subject to change without notice.