

Track Cable Cylinder

TC05 1/2" Bore

1001-4009_06

Replaced #1001-0230 & #1001-0234

MODELS: TC05
TCM05

Part Numbers noted for Repair Kits and Cable Assemblies are for standard cylinders only. Always make reference to the complete configuration number and stroke length of your cylinder when ordering replacement items.

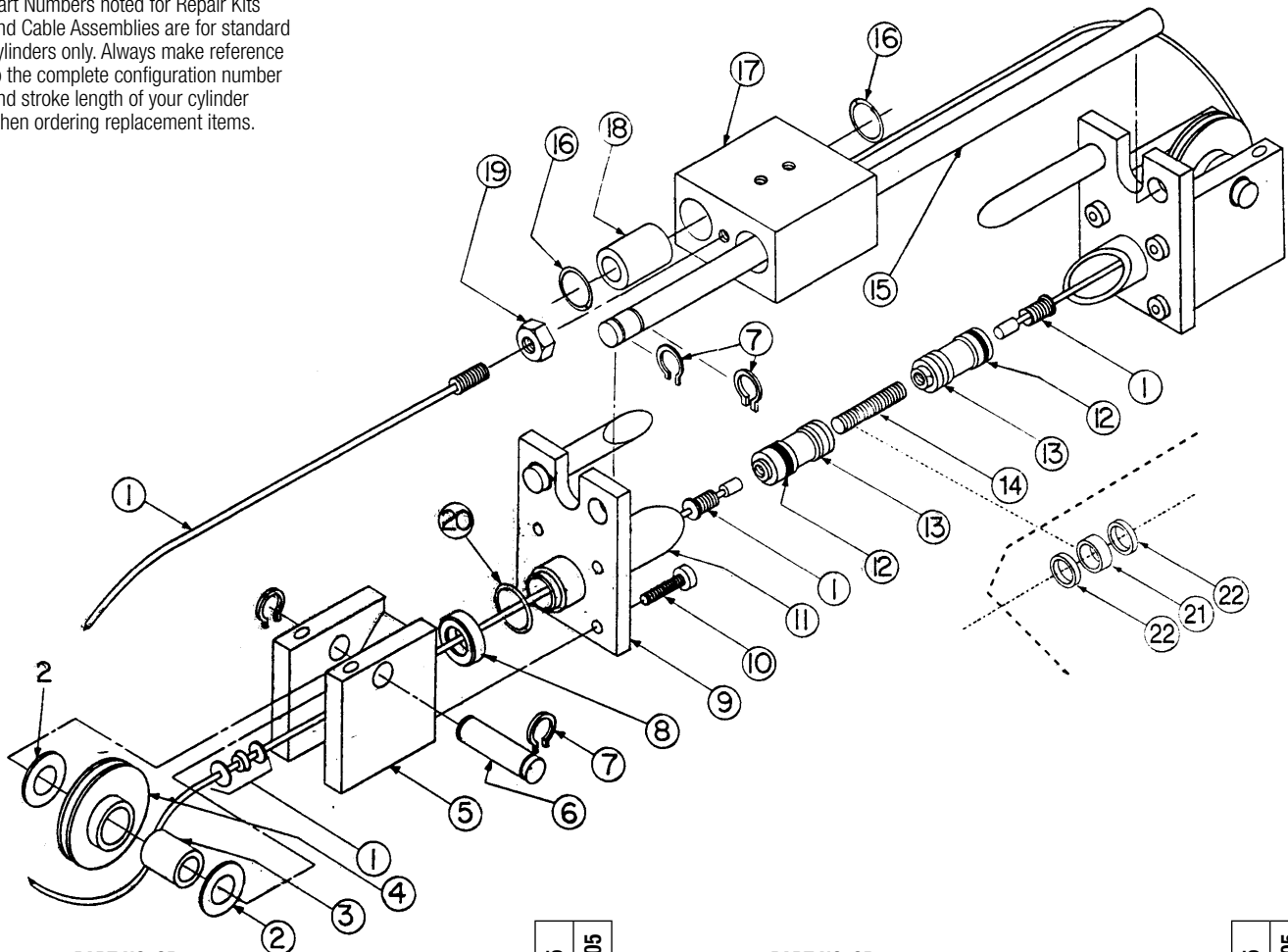

ITEM	PART NO. OR CONFIG. CODE	DESCRIPTION	TC05	TCM05
^{2,3} 1.	CATC05SK_	CABLE ASSEMBLY	2	
	CATCM05SK_	CABLE ASSEMBLY W/ MAGNET		2
2.	0100-1306	THRUST RACE	4	4
3.	1001-1055	NEEDLE BEARING	2	2
4.	1050-9005	PULLEY ASSEMBLY	2	2
5.	1085-1005	CYLINDER HEAD, SINGLE PORT	2	2
	1001-1109	GLAND INSERT	2	2
6.	1001-1052	PULLEY SHAFT	2	2
7.	1001-1056	EXTERNAL RETAINING RING	8	8
³ 8.	1085-1025	TUBE SEAL, BUNA-N MATERIAL	2	2
	1085-1025	TUBE SEAL, VITON® MATERIAL	2	2
9.	1085-1050	CLAMP PLATE	2	2
10.	1085-1075	SOCKET HEAD CAP SCREW	8	8
¹ 11.	RTBTC05SK_	ALUMINUM TUBE	1	
	RTBTCM05SK_	ALUMINUM TUBE W/ MAGNET		1

ITEM	PART NO. OR CONFIG. CODE	DESCRIPTION	TC05	TCM05
³ 12.	1080-1020	PISTON U-CUP, BUNA-N MATERIAL	2	2
	1080-1020	PISTON U-CUP, VITON® MATERIAL	2	2
13.	1085-1040	PISTON	2	2
14.	1001-1194	PISTON SPACER	1	
¹ 15.	1001-1231	PISTON SPACER WITH MAGNET		1
	NGSTC05SK_	GUIDE SHAFT	2	
	NGSTCM05SK_	GUIDE SHAFT W/ MAGNET		2
16.	1001-1199	INTERNAL RETAINING RING	4	4
17.	1001-1197	BEARING BLOCK	1	1
18.	1001-1192	LINEAR BEARING	3	3
19.	1004-1188	JAM NUT	2	2
20.	1085-1018	EXTERNAL RETAINING RING	2	2
21.	1080-1012	MAGNET RING		1
22.	1085-1042	ROD, SPACER, PISTON		2

¹ Replacement Tube (RTB) & Guide Shaft (NGS) ordering method: **TIC** **M** **05** **SK**

EXAMPLE: RTB TIC M 05 SK 21 25

² Repair Kit (RK) & Cable Assembly (CA) ordering method: **TIC** **M** **05** **SK**

EXAMPLE: RK TIC M 05 SK 21 25

Repair Kit Model Size Stroke Length

³ Repair Kit (RK) includes: Piston U-Cups, Quad Rings, O-Rings, Cable Assembly

⁴ **M** is for optional switch magnet, which is required for switches to function. Since the Magnet Option adds length to the piston and the tube length, it must be included when ordering.

Drawing repeated for reference

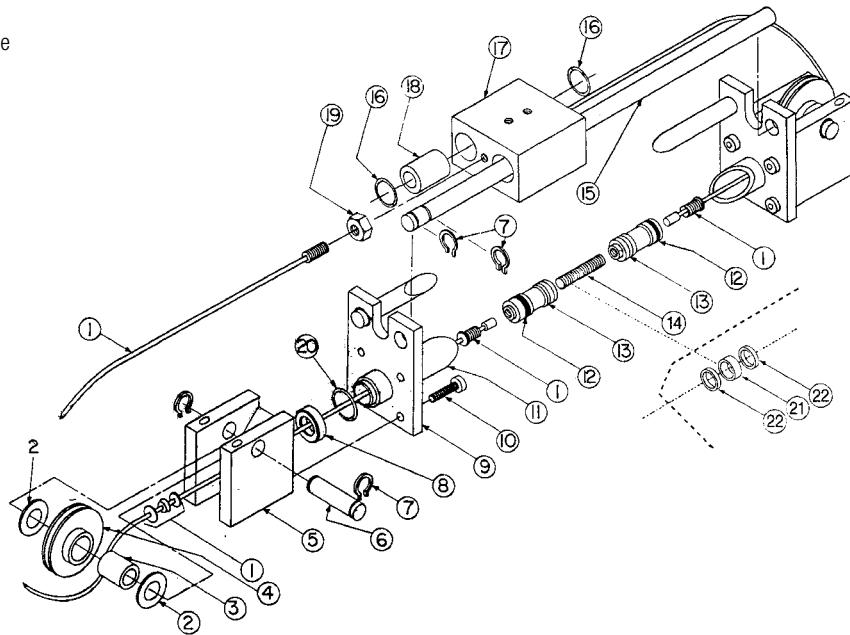

Installation

When unpacking a track cable cylinder, BE EXTRA CAREFUL NOT TO SCRATCH OR MAR THE NYLON COVERING ON THE CABLE. The cylinder may be mounted by use of the bolt holes in head. When attaching the bearing block to a driven mechanism, be sure it is in perfect alignment and that the load does not exceed the specifications listed in the catalog.

Pretensioning and proof-loading instructions: All track cable cylinders are shipped without being pretensioned. They must be tensioned after mounting to insure the maximum service life of the unit. There are two types of stretch in cable— constructional and elastic. The constructional stretch is removed by proof-loading of the cable. The elastic stretch is removed by proper pretensioning of the cable.

Proof-loading of cables (for cylinders without Auto Tensioners)

1. Tighten the bracket terminal lock nuts equally with a torque wrench to torque requirements listed in Table A.
2. Let set for 30 seconds.
3. Loosen lock nuts to remove tension. (But leave them tight enough to eliminate any slack.)
4. Follow Pretensioning Instructions.

MODEL	REQUIRED TORQUE
TC05	15 INCH-POUNDS (1.69 NEWTON-METERS)

Pretensioning of cables

1. Remove one of the guide shafts to gain access to the terminals to adjust the cable tension.
2. Block the load some distance from the end of travel to keep the cylinder from bottoming.
3. Apply pressure 15 to 20 percent higher than the actual pressure required to move the load.

NOTE: Load pressure is defined as the actual pressure required to move the load. When the load is stopped externally before the piston bottoms, the relief valve or regulator setting becomes the load pressure.

When pressurized, one cable will become tight while the other becomes slack. Manually take up the slack in the cable. Release the pressure and block the load from the other side. Repeat the manual adjustment on the other cable. Release pressure and remove the blocks. Reinstall the guide shaft which had been removed. Return the regulator to its original setting.

The cylinder is now pretensioned. Additional manual adjustment should not be required. It is suggested however, that the cable tension be checked periodically.

Alternate Method: If the load cannot be blocked for cable pretensioning as stated above, tighten the bracket terminal lock nuts with a torque wrench to total pretensioning torque as stated in Table B.

MODEL	PRETENSIONING TORQUE	+	STARTING TORQUE OF TERMINAL NUTS	=	TOTAL PRETENSIONING TORQUE
TC05	2.5 IN-LBS.	+	10.0 IN.-LBS.	=	12.5 IN.-LBS.
	0.282 N-M	+	1.130 N-M	=	1.412 N-M

TO REBUILD THE CYLINDER

1. Remove the track cable cylinder from machinery.
2. Remove the Guide Shafts (15) then disconnect Cables (1) from Bearing Block (17) and remove Pulleys (4) on both ends of track cable cylinder.
3. Remove one Head (5) from track cable cylinder by removing the four Cap Screws (10).
4. Pull Piston (13) towards the removed Cylinder Head (5) and remove from the Tube (11).
5. Disconnect Cables (1) from Piston (13). (See Cable Assembly/Disassembly Instructions). Then remove the other Cylinder Head (5) from Tube (11) and disengage Cable (1) from it.
6. Install new U-cups (12) Pistons (13).
7. See Cable Assembly/Reassembly Instructions below. Always lubricate seals with oil when installing.

8. Put one Cable (1) end through each Cylinder Head (5). Reattach one head tube and connect the end of one Cable (1) to the Piston (13). Then connect the other Cable (1) to the Piston (13).
9. Push Piston (13) back into Tube (11) by gently tucking in the U-cup (12). Mount Cylinder Head (5) back on cylinder with the Cap Screws (10). Replace Pulleys (4) and connect Cables (1) to Bearing Block (17).
10. Pretension Cables (1) according to the pretensioning instructions.
11. Operate track cable cylinder back and forth by hand several times to be sure it is properly assembled before applying pressure.
12. Reinstall track cable cylinder on machinery.

IMPORTANT NOTE: Apply (Blue) Loctite® #242 or equivalent to threaded cable terminal before connecting to the piston.

SNAP IN/OUT CABLE ASSEMBLY INSTRUCTIONS

Tolomatic cylinders with 1/2-, 3/4- and 1-inch bores are designed to allow assembly and disassembly of Cables from the heads without the use of tools. This eliminates the possibility of damaging the cable or seals as well as providing for quick repair times.

Disassembly

1. Holding onto cylinder Head (6), pull Piston Terminal (1) until bracket terminal in (8) is against Washer (4).
2. Put a small amount of slack in Cable (7) as shown in Figure 2.
3. Impart a “snap” action to Piston Terminal (1).
4. With the imparting snap action, Washer (2) will release allowing the removal of the complete cable assembly.

Reassembly

1. Holding onto cylinder Head (6), string Bracket Terminal (8) through Gland (5) until Washer (4), U-cup (3) and Washer (2) are held flush against one another by Piston Terminal (1).
2. Put a small amount of slack in Cable (7) as shown in Figure 3.
3. Impart a “snap” action to Bracket Terminal (8).
4. With the snap, Washer (2) will snap into Gland (5).
5. Move the cable in the opposite direction as shown in Figure 3, to verify if Washer (2) is seated in Gland (5). If not, repeat steps 1-4.

MAINTENANCE

Keep the cylinder as clean as possible around pulleys, glands, etc. Pneumatic service should be adequately lubricated with SAE 10 or 20 grade non-detergent oil. Pulleys have permanently lubricated bearings and will require no maintenance. Check the cylinder's cables periodically to help prevent premature or unexpected failures.

Your Tolomatic Cable Cylinder will give you many cycles of trouble free service. However, should a leak occur, a rebuilding kit may be obtained which enables you to replace all the seals in a cylinder to return it to normal operating condition.

NOTE: Every Tolomatic Cable Cylinder has its stroke length indicated on the identification tag shipped with the cylinder. Refer to this stroke measurement when ordering replacement parts for the cylinder.

Should the tag be missing, measure the length of the cylinder including the heads at both ends. If there are no switches present on the cylinder, check the piston for a magnet to see if it is a Reed Switch model. If it is, consult the Tolomatic Cable Cylinder catalog dimensional drawings for “stroke-plus” length and subtract 1.62 inches for cylinders with 1/2-inch 3/4-inch and 1-inch bores and .375 inches for all larger bore Reed Switch models to determine the stroke length.

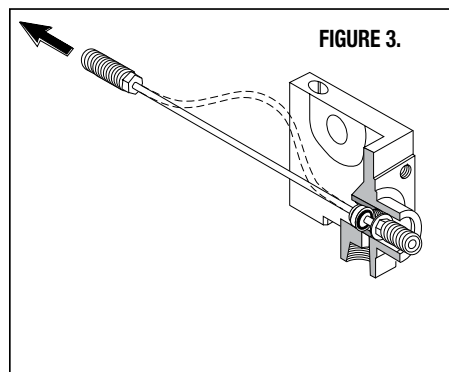
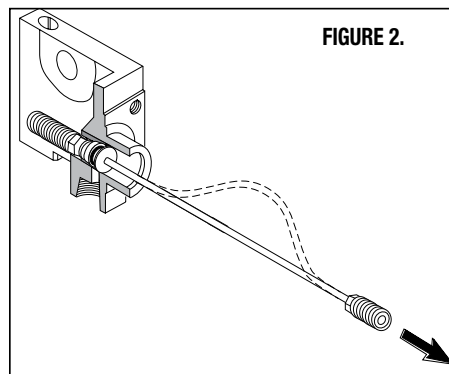
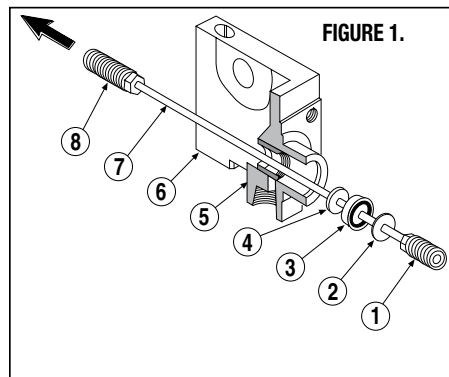

REED SWITCHES

NOTE: Form A Reed Switches should not be used in TTL logic circuits. A voltage drop caused by the L.E.D. indicator will result. For applications where TTL circuits are used, please contact Tolomatic.

WARNING: An ohmmeter is recommended for testing Reed Switches. NEVER use an incandescent light bulb as a high current rush may damage the switch. Reed and TRIAC switches are only recommended for signalling position, not directly powering solenoids. For shifting a solenoid, a relay or resistor is recommended instead of the switch. Switch ratings must not be exceeded at any time

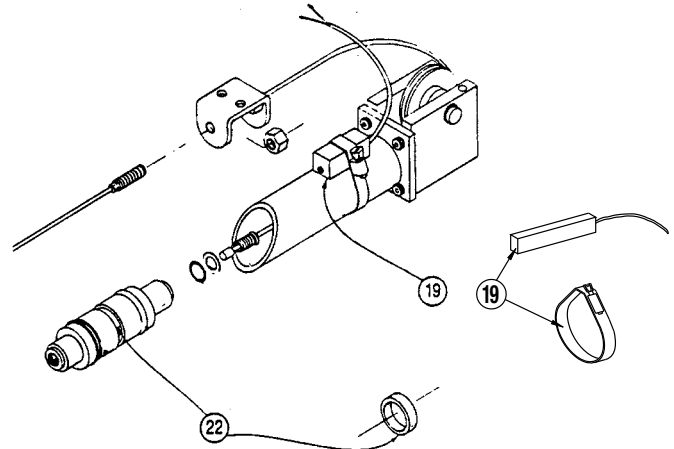

CONFIG. CODE ORDERING		
MOUNTING HARDWARE & FE CONN. INCLUDED		
ITEM	CODE	DESCRIPTION
19.	BT	SWITCH KIT, REED, FORM C, 5M
	BM	SWITCH KIT, REED, FORM C, QD MALE CONN.
	RT	SWITCH KIT, REED, FORM A, 5M
	RM	SWITCH KIT, REED, FORM A, QD MALE CONN.
	CT	SWITCH KIT, TRIAC, 5M
	CM	SWITCH KIT, TRIAC, QD MALE CONN.

ITEM	PART NO.	DESCRIPTION	QUANTITY	
			TC05	TCM05
22.	1075-1019	MAGNET		1

NOTE: When ordered female connector & all mounting hardware is included

To Order Retrofit Kits

All Switch Kits come with 1 switch and mounting hardware.

Retrofit ordering method: **SW TIC**

EXAMPLE: **SW TIC 60 RT**
 Switch Kit Model Size Switch Type Code

Universal Switch Wiring Diagrams and Label Color Coding

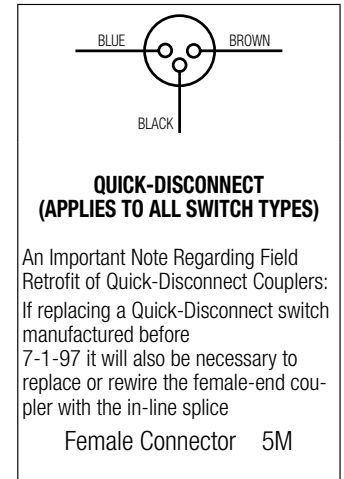
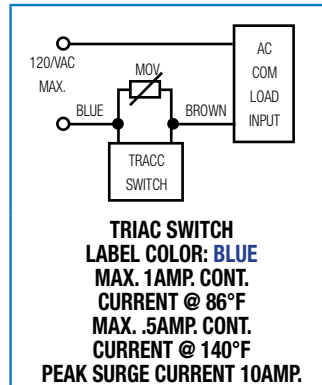
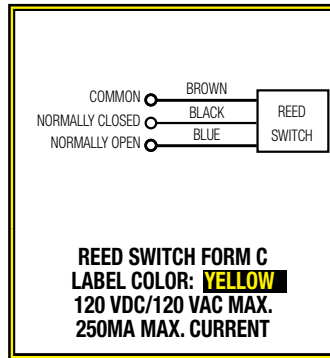
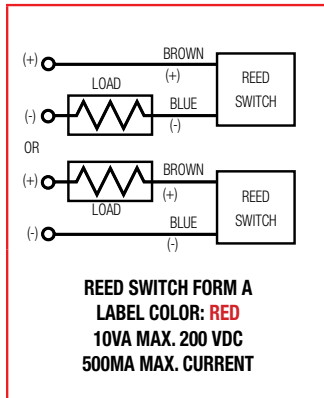

NOTE: The side of the switch with the groove indicates the sensing surface. This must face toward the magnet.

For complete Reed and TRIAC Switch Performance Data, refer to the [Tolomatic Pneumatic Products Catalog](#).

Loctite® is a registered trademark of the Loctite Corporation, www.loctite.com
 Viton® is a registered trademark of the E.I. Du Pont de Nemours Co., www.dupont.com

SWITCH TYPE CODE	
BT	FORM C REED SWITCH WITH 5-METER LEAD
BM	FORM C REED SWITCH WITH 5-METER LEAD AND QD
RT	FORM A REED SWITCH WITH 5-METER LEAD

SWITCH TYPE CODE	
RM	FORM A REED SWITCH WITH 5-METER LEAD AND QD
CT	TRIAC SWITCH WITH 5-METER LEAD
CM	TRIAC SWITCH WITH 5-METER LEAD AND QD



3800 County Road 116, Hamel, MN 55340 USA
<http://www.Tolomatic.com> • Email: Help@Tolomatic.com
 Phone: (763) 478-8000 • Fax: (763) 478-8080 • Toll Free: 1-800-328-2174

COMPANY WITH
 QUALITY SYSTEM
 CERTIFIED BY DNV GL
 = ISO 9001 =

All brand and product names are trademarks or registered trademarks of their respective owners. Information in this document is believed accurate at time of printing. However, Tolomatic assumes no responsibility for its use or for any errors that may appear in this document. Tolomatic reserves the right to change the design or operation of the equipment described herein and any associated motion products without notice. Information in this document is subject to change without notice.