

# Power Block Rod Cylinder Slide

PB06 — 3/8" BORE

**(12-20-2019) DISCONTINUED PRODUCT STYLE OR SIZE. PARTS SHEET IS FOR REPAIR INSTRUCTIONS ONLY.**

Parts listing is for reference only. All parts listed are limited to stock on hand. Contact Tolomatic regarding availability.

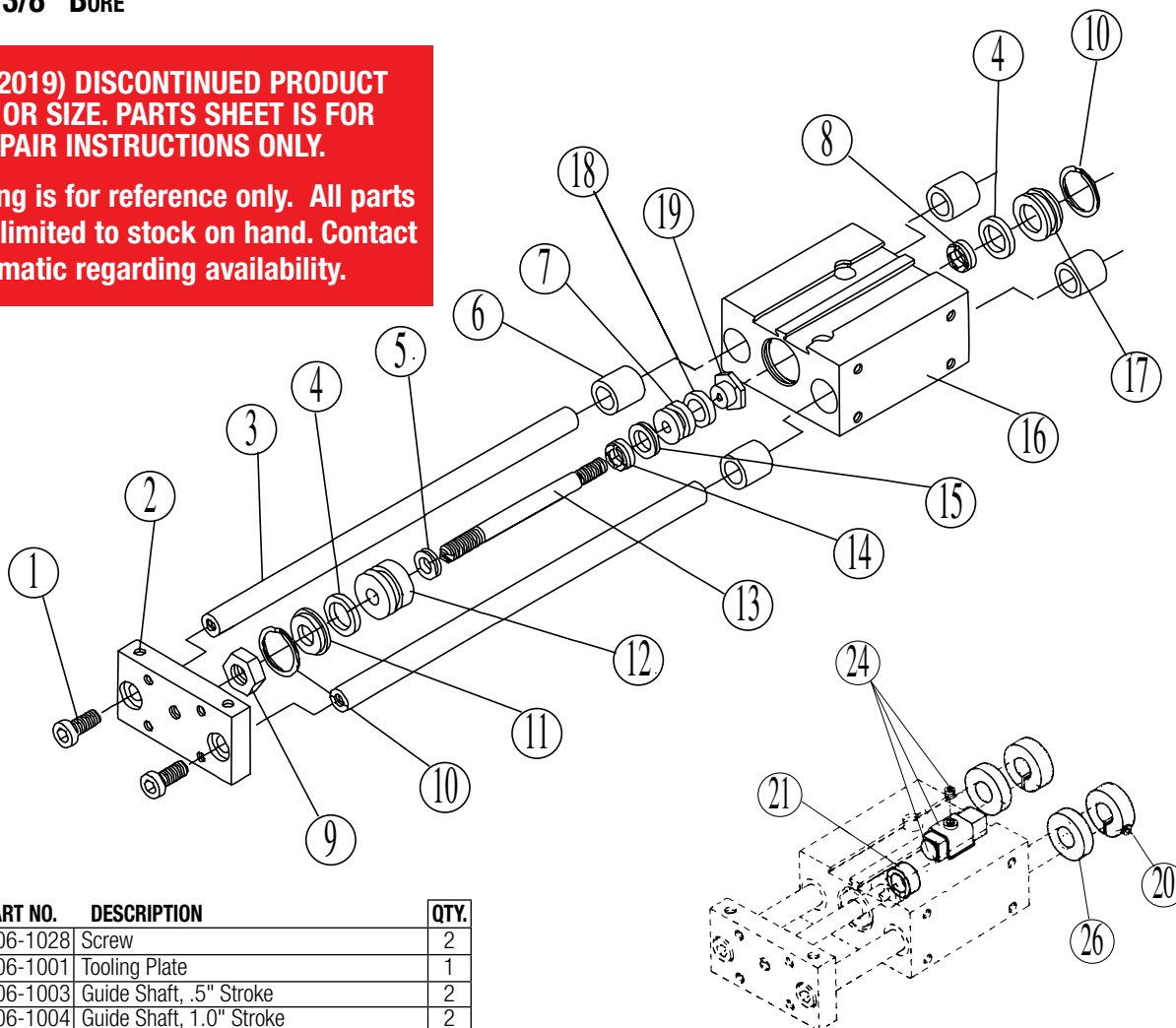

ITEM	PART NO.	DESCRIPTION	QTY.
1.	2506-1028	Screw	2
2.	2506-1001	Tooling Plate	1
3.	2506-1003	Guide Shaft, .5" Stroke	2
	2506-1004	Guide Shaft, 1.0" Stroke	2
	2506-1005	Guide Shaft, 1.5" Stroke	2
	2506-1006	Guide Shaft, 2.0" Stroke	2
§ 4.	1014-1062	O-Ring	2
§ 5.	2506-1021	Quad Ring	1
6.	2506-1025	Plastic Bearing	4
7.	2506-1013	Piston	1
§ 8.	2406-1021	Polyurethane Bumper	1
9.	2506-1007	Hex Jam Nut	1
10.	2506-1029	Retaining Ring	2
11.	2506-1023	Steel Washer	1
12.	2506-1014	Head	1
13.	2506-1008	Piston Shaft, .5" Stroke	1
	2506-1009	Piston Shaft, 1.0" Stroke	1
	2506-1010	Piston Shaft, 1.5" Stroke	1
	2506-1011	Piston Shaft, 2.0" Stroke	1
	§ 14.	2506-1022	Bumper
§ 15.	2506-1020	O-Ring	1
16.	2506-1016	Base, .5" Stroke	1
	2506-1017	Base, 1.0" Stroke	1
	2506-1018	Base, 1.5" Stroke	1
	2506-1019	Base, 2.0" Stroke	1
17.	2506-1015	Cap	1
18.	2506-1042	Spacer (for use without magnet)	1

ITEM	PART NO.	DESCRIPTION	QTY.
***19.	2506-1038	Lock Nut	1
***20.	2506-1026	Shaft Collar	2
*21.	2403-1008	Hall Magnet	1
	2403-1008	Reed Magnet	1
Switches			
**24.	RT	Switch, Reed Fm A, 5 M Wire	A/R
	RM	Switch, Reed, Fm A, Male Conn.	A/R
	BT	Switch, Reed, Fm C, 5 M Wire	A/R
	BM	Switch, Reed, Fm C, Male Conn	A/R
	CT	Switch, Triac, 5M Wire	A/R
	CM	Switch, Triac, Male Connect	A/R
	TT	Switch, Source, Hall-effect, 5 M Wire	A/R
	TM	Switch, Source, Hall-effect, Male Cn	A/R
	KT	Switch, Sinking, Hall-effect, 5 M Wire	A/R
	KM	Switch, Sinking, Hall-effect, Male Cn	A/R
***26.	2506-1027	Bumper	2

\* Magnet Option.

\*\* Included in Switch Option Kit.

\*\*\* Included in Bumper Option Kit 2506-9002.

§ Contained in repair kit 2506-9016.

1. Unscrew and remove the Tooling Plate (#2).
2. Remove the Retaining Ring (#10) from the inside center bore of the Base (#16) and remove the entire piston assembly from the base.
3. Remove the Hex Jam Nut (#9) from the Piston Shaft (#13) and slide the Retaining Ring (#10), the Steel Washer (#11), and the Head (#12) off of the piston shaft and set aside.
4. Remove the O-Ring (#4) from the head and replace with a new O-Ring.
5. Remove the Wiper Seal/O-Ring (#5) from the head. Fill the empty groove in the head with Magnalube®-G and place a new Wiper Seal/O-Ring into the groove.
6. Slide the Bumper (#14) and the O-Ring (#15) off of the piston shaft and replace with a new O-Ring and bumper.
7. At the other end of the unit, pry off the Retaining Ring (#10) and remove the Cap (#17).
8. Pry the Bumper (#8) out of the recess in the cap and throw away. Apply Loctite® #495 into the recess in the cap and press a new bumper into the recess.
9. Apply Magnalube®-G to the inside of the piston bore and slide the piston and shaft assembly back into the bore from the rear of the unit.
10. Place a thin coat of Magnalube®-G onto the Piston Shaft (#13) and slide the Head (#12) onto the shaft with the end containing the Wiper Seal/O-Ring (#5) facing away from the piston.
11. Slide the Steel Washer (#11) and Retaining Ring (#10) back onto the piston shaft and snap the retaining ring into the base.
12. Apply Loctite® #242 to the threads\* of the Hex Jam Nut (#9) and replace onto the end of the shaft.  
\*Before applying Loctite be sure threads are free of oil.
13. Apply Loctite® #242 to the screw holes in the Tooling Plate (#2) and assemble the tooling plate to the piston and guide shafts using the original screws (Torque to 36 -42 in.lbs.).
14. Push the cap back into the center bore in the base and replace the retaining ring in the groove behind the cap.

15. SWITCHES

**NOTE:** Form A Reed Switches should not be used in TTL logic circuits. A voltage drop caused by the L.E.D. indicator will result. For applications where TTL circuits are used, please contact Tolomatic.

**WARNING:** An ohmmeter is recommended for testing Reed Switches. NEVER use an incandescent light bulb as a high current rush may damage the switch.

Reed and TRIAC switches are only recommended for signalling position, not directly powering solenoids. For shifting a solenoid, a relay or resistor is recommended between it and the switch. Switch ratings must not be exceeded at any time.

**TO ORDER RETROFIT KITS:** SW (then the model number and base size, and code for type of switch needed: **EXAMPLE: SWPB06BT**)

Where SW is the switch kit, PB is the model, 06 is the 3/8" size, and BT is a Form A Reed Switch with 5-meter lead.

All Switch Kits come with 1 switch and mounting hardware.

Loctite® is a registered trademark of the Loctite Corporation, www.loctite.com

Magnalube®-G is a registered trademark of the Carleton-Stuart Corporation, www.magnalube-g.com

CONFIG. CODE ORDERING	
Mounting Hardware & FE conn. included	
CODE	DESCRIPTION
BT	Switch Kit, Reed, Form C, 5m
BM	Switch Kit, Reed, Form C, Male Conn.
RT	Switch Kit, Reed, Form A, 5m
RM	Switch Kit, Reed, Form A, Male Conn.
CT	Switch Kit, Triac, 5m
CM	Switch Kit, Triac, Male Conn.
KT	Switch Kit, Hall-effect, Sinking, 5m
KM	Switch Kit, Hall-effect, Sinking, Male Conn.
TT	Switch Kit, Hall-effect, Sourcing, 5m
TM	Switch Kit, Hall-effect, Sourcing, Male Conn.

NOTE: When ordered female connector & all mounting hardware is included

Switch Wiring Diagrams and Label Color Coding

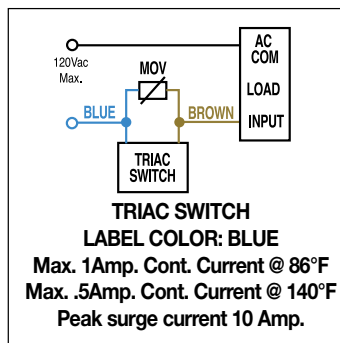
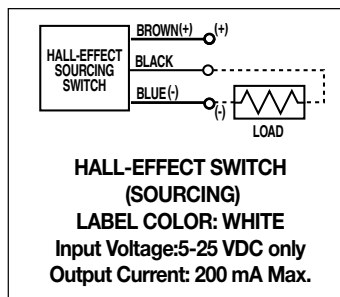
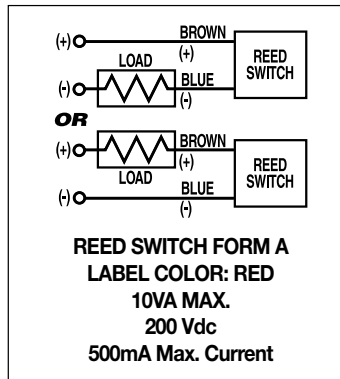

For complete Reed and TRIAC Switch Performance Data, refer to the Tolomatic Pneumatic Products Catalog #9900-4000.

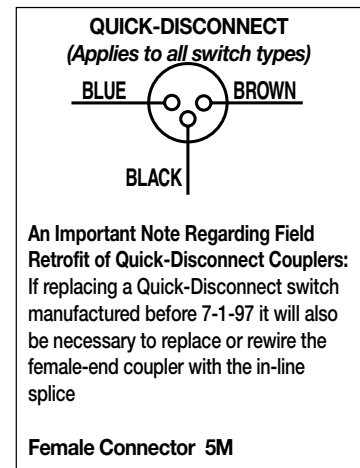
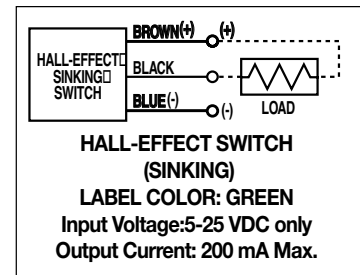
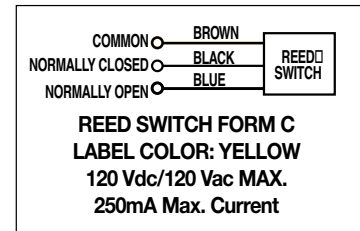

**NOTE:** The side of the switch with the groove indicates the sensing surface. This must face toward the magnet.



COMPANY WITH  
 QUALITY SYSTEM  
 CERTIFIED BY DNV GL  
 = ISO 9001 =

3800 County Road 116, Hamel, MN 55340 USA  
 http://www.Tolomatic.com • Email: Help@Tolomatic.com  
 Phone: (763) 478-8000 • Fax: (763) 478-8080 • Toll Free: 1-800-328-2174

All brand and product names are trademarks or registered trademarks of their respective owners. Information in this document is believed accurate at time of printing. However, Tolomatic assumes no responsibility for its use or for any errors that may appear in this document. Tolomatic reserves the right to change the design or operation of the equipment described herein and any associated motion products without notice. Information in this document is subject to change without notice.