





**General Disassembly Instructions:**

1. Remove the Band Clamps (7) to free the ends of the Dust Band (19). If desired the Dust Band (19) can be completely removed by removing both End Caps (43) from the Carrier (42).
2. Remove idle head Cover Plates (9). Remove Set Screws (12), then both belt Tension Screws (52).
3. Remove any motor mounting hardware to expose the Driveshaft (48). Remove Fasteners (5) holding the drive Bearing Plates (4) on the Head (2).
4. Pull one drive Bearing Plate (4) off of the head. It may be necessary to press on one end of the Driveshaft Assembly (48) to push the Driveshaft Assembly (48) out of the plate. The Bearing Plates (4) are held to the drive Bearings (6) with Loctite 641 retaining compound. Note that the Bearing (6) may come off the Driveshaft (48), in which case the Bearing (6) can then be pressed out of the Bearing Plate (4) from the opposite side.
5. Remove the other Bearing Plate (4) and/or Driveshaft Assembly (48). The Driveshaft Assembly (48) can then be pressed out of the Bearing Plate (4).
6. At the idle end, the Pulley (13), Bearings (16), and Spacers (15) can now be removed by sliding the Idle Shaft (14) out of the Yoke (11).
7. Remove the head Fasteners (3) and the drive end Head (2). Remove the Fasteners (27) to free the Belt Bracket (26) from the Carrier (42). Position the Belt Bracket (26) all the way to the end of Tube (1) where the Head (2) has been removed, to expose all fasteners. Remove the belt clamp Fasteners (29,30), from one end of the Belt (46). The Belt Bracket (26) and the Belt (46) can now be removed from the assembly.
8. Remove the other belt clamp Fasteners (29,30) and remove all hardware from the Belt (46).

**General Assembly Instructions:**

\*Apply Loctite #242 to all fasteners upon installation

1. Slide the Belt (46) through the bottom section of the Tube (1) TEETH FACING UP.
2. Attach both ends of the Belt (46) to the Bracket (26) using the 2 Belt Clamps (28) and the Socket Head Cap Screws (30) through the Belt Clamp (28), and the Flat Head Screws (29) into the sides of the Belt Clamp (28).
3. The teeth of the Belt (46) should mate with the teeth of the Belt Clamp (28), and be inserted into the Belt Clamp (28) as far as possible to maximize engagement of the teeth.
4. \*Orientation of Heads (2) on the Tube (1), when viewed from motor end of actuator with primary Carrier (42) up, the wedge side will be to the left.
5. Position the idle Pulley (13) inside the Belt (46) at the end of the Tube (1). Position the Yoke (11) over the Pulley (13), and slide the Idle Shaft (14) through the Yoke (11) such that a Spacer (15) is on either side of the Pulley (13) yet inside the Yoke (11).
6. Position the Head (2) over the Pulley (13)/Yoke (11) and install Head (2) onto Tube (1) with 4 Fasteners (5). Align the Head (2) to the Tube (1) using a flat plate, to ensure that the top of the Head (2) is aligned flush with the top of magnet band surface of the Tube Assembly (1).
7. Start the 2 Tension Screws (52) into the Yoke (11) through the Head (2).
8. Mount the drive Head (2) to the Tube (1) with Fasteners (3).
9. Apply a coating of loctite 641 and primer N to the OD of the Bearing (6) that's located against the shoulder of the Driveshaft (48). Apply a coating of loctite 641 to the ID bore of one of the drive Bearing Plates (4). Install the Bearing (6) into the bore of the Bearing Plate (4) making sure it is completely bottomed out. Wipe away any excess loctite.

10. Install the Bearing Plate (4)/Driveshaft Assembly (48) onto the drive Head (2) with 4 Fasteners (5), positioning the pulley through the Belt (46). \*Note that the center line of the Driveshaft (48) is not symmetrical within top and bottom of the Bearing Plate (4). Install with the Driveshaft (48) nearest the bottom of the Head (2). \*The side at which the Driveshaft Assembly (48) is attached to the Head (2) determines left/right drive shaft orientation. Install in the desired orientation.
11. Apply a coating of loctite 641 and primer N to the OD of the exposed Bearing (6). Apply a coating of loctite 641 to the ID of the Bearing Plate (4) bore, and install the non-drive side Bearing Plate (4) onto the Head (2) with 4 Fasteners (5).
12. Insert plastic Plugs (47) into the holes in the end of the drive Head (2).
13. Secure Carrier Assembly (42) to the Belt Bracket Assembly (26). If unit has an auxiliary carrier attach Belt Bracket (26) to the Carrier (42) nearest the motor end.

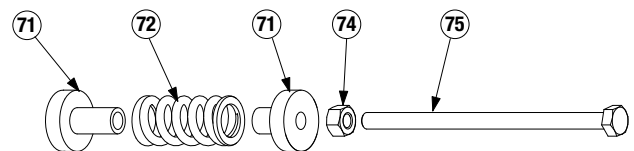
**Belt Tensioning (Kit #3420-9410):**

1. On the belt tension tool ensure that the Nut (74) is positioned on the Tension Screw (75) such that it is making contact with the head of the Tension Screw (75). Thread it into this position as needed.
2. Thread the belt tension tool assembly into the Yoke (11) at the idle end until the face of the Spring Standoff (71) makes contact with the actuator Head (2).
3. While holding the Tension Screw (75) from turning, thread the Nut (74) down the Tension Screw (75) until the Spring Standoff (71) makes contact with the opposing Spring Standoff (71). \*Caution: Do not tighten past the point of contact being made. This will result in over tension.
4. Adjust the 2 Tension Screws (52) that hold the Yoke (11) in place. View the Yoke (11) through the side of the Head (2) and snug each fastener such that the Yoke (11) is visually parallel to the bottom surface of the Head (2).
5. Install and tighten down the 2 Set Screws (12) to hold the Tension Screws (52) in place.
6. Remove pressure from the tensioning tool and unscrew its shaft out of the Yoke (11).
7. Install plastic Plug (24) button into hole in end of the idler Head (2).
8. Attach the Bumpers (24) to drive and idler Heads (2) as needed. Note: If there is a machined recess in the bumper assembly it is to be assembled against the surface of the head. \*Verify there is no contact between the bumper and belt material when assembled.
9. Replace the ends of the Dust Band (19) to their location and install the Band Clamps (7).

**Bearing lubrication**

The bearing system is pre-lubricated at the factory with Mobil HP grease. Re-lubrication is recommended every .5-1 million cycles using a lithium-soap base grease for optimal bearing performance. To re-lubricate, remove Set Screws (8) and SHCS (51), Band Clamp (7). Lift back Dust Band (19) and apply grease directly to the stationary ball ways.

For special lubrication option grease, email [help@tolomatic.com](mailto:help@tolomatic.com)

## Reverse Parallel (RP) Mounting Option

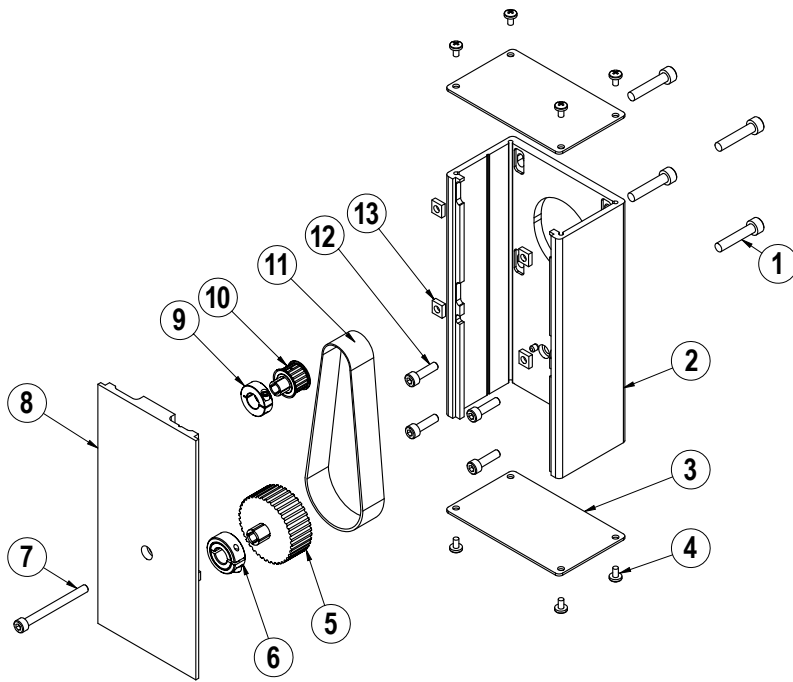

ITEM	PART NO.	DESCRIPTION	QTY.
◊1.	CONFIGURED	MOTOR FASTENER	4
◊2.	CONFIGURED	RP HOUSING	1
◊3.	CONFIGURED	RP HOUSING END CAP	2
◊4.	CONFIGURED	END CAP SCREW	8
◊5.	CONFIGURED	DRIVE SHAFT PULLEY	1
◊6.	CONFIGURED	COLLAR CLAMP, DRIVE SHAFT	1
◊7.	CONFIGURED	RP COVER FASTENER	1
◊8.	CONFIGURED	RP COVER	1
◊9.	CONFIGURED	COLLAR CLAMP, MOTOR	1
◊10.	CONFIGURED	MOTOR PULLEY	1
◊11.	CONFIGURED	BELT	1
◊12.	CONFIGURED	RP PLATE FASTENER	4
◊13.	CONFIGURED	SQUARE NUT	4

◊ Part numbers varies depending on YMH (Your Motor Here). Contact [help@tolomatic.com](mailto:help@tolomatic.com) for replacement part numbers.

### Disassembly Instructions

1. Remove End Caps (3), and release the tension on the Belt (11) by breaking loose the motor fasteners (1).
2. Remove the RP Cover (8).
3. The Belt (11) can now be removed along with the Motor.
4. Remove both Pulleys (10) and (5) from their respective shafts.
5. Remove the RP Housing (2) from the actuator head by removing the Fasteners (12).

### Assembly Instructions

Note: Apply Loctite #242 to all fasteners upon installation

1. Install RP Housing (2) onto the actuator Head with Fasteners (12).  
**Note:** If the RP housing has a bearing in it do not fully tighten the fasteners at this time. Instead temporarily install the RP cover (8) onto the RP case, positioning the bearing over the leadscrew shaft. Hold the cover in place while tightening all the Fasteners (12) so that the case is snug. Then remove the RP cover and finish tightening the fasteners
2. Install the Motor to the RP Housing with Fasteners (1) and Square Nuts (13). Do not tighten the fasteners at this time.
3. Locate the Belt (11) over the Pulleys (10) and (5) and slide both pulleys over their respective shafts. Tighten each pulley to its shaft with the Collar Clamps (9) and (6).

4. Tension the Belt (11) by pulling the motor away from the drive shaft with the appropriate tension force shown in the chart below. While tensioning, the actuator should be positioned so the weight of the motor does not affect the belt tension. Tighten the Motor Fasteners (1) while the tensioning force is applied to the motor.

SMALLEST SHAFT DIAMETER (Motor or Actuator)		TOTAL WEIGHT TO APPLY	
Inches	mm	lbs	kgs
0.18 to 0.259	4.572 to 6.579	13	5.902
0.260 to 0.499	6.604 to 12.675	22	9.988
0.500 to 0.625	12.7 to 15.875	31	14.074
0.625 and larger	15.875 and larger	40	18.160

Additional tips are found in Tolomatic [Electric Actuator Motor Mounts Technical Note # 3600-4203](#).

5. Verify that there is clearance between the inside of the RP case and each pulley. Verify the pulleys are aligned to each other.
6. Position the Cover (8) in the mating slot of the RP case and install the Fasteners (7) to hold it in place. Take care not to overtighten. If the cover is deflected, it can interfere with the leadscrew.
7. Install both End Caps (3) with the Screws (4) to finalize the assembly.







**SWITCH KIT**

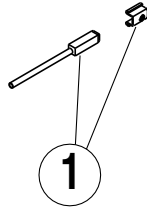

**ITEM**

SWITCH KIT SWB320SK (US CONV) SWB3W20SM (METRIC)	
CONFIG. CODE ORDERING	
CODE	DESCRIPTION
BT	SWITCH KIT, REED, FORM C, 5M
BM	SWITCH KIT REED, FORM C, QUICK DISCONNECT
RT	SWITCH KIT, REED, FORM A, 5M
RM	SWITCH KIT, REED, FORM A, QUICK DISCONNECT
CT	SWITCH KIT, TRIAC, 5M
CM	SWITCH KIT, TRIAC, QUICK DISCONNECT
KT	SWITCH KIT, HALL-EFFECT, SINKING, 5M
KM	SWITCH KIT, HALL-EFFECT, SINKING, QUICK DISCONNECT
TT	SWITCH KIT, HALL-EFFECT, SOURCING, 5M
TM	SWITCH KIT, HALL-EFFECT, SOURCING, QUICK DISCONNECT

**NOTE:** Switch bracket, set screw, & mating QD cable is included

2. **Switches.** Secure Switch (1) to magnet side of Tube with Switch Clamp (2) and Set Screw.

**3. SWITCHES**

**REED SWITCHES**

**NOTE:** Form A Reed Switches should not be used in TTL logic circuits. A voltage drop caused by the L.E.D. indicator will result. For applications where TTL circuits are used, please contact the factory.

**WARNING:** An ohmmeter is recommended for testing Reed Switches. NEVER use an incandescent light bulb as a high current rush may damage the switch.

**TO ORDER RETROFIT KITS:**

SW then the model number and base size, and code for type of switch needed:

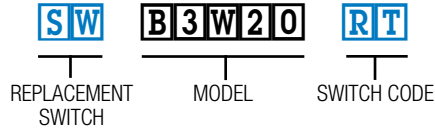

Where SW is the switch, B3W20 is the 2 inch size, and RU is a Form A Reed Switch with quick disconnect and 5 meter lead

All switch kits include 1 switch and mounting hardware

Reed and TRIAC switches are only recommended for signalling position, not directly powering solenoids. For shifting a solenoid, a relay or resistor is recommended between it and the Reed Switch. Switch ratings must not be exceeded at any time.

**TUBE SUPPORT KIT**

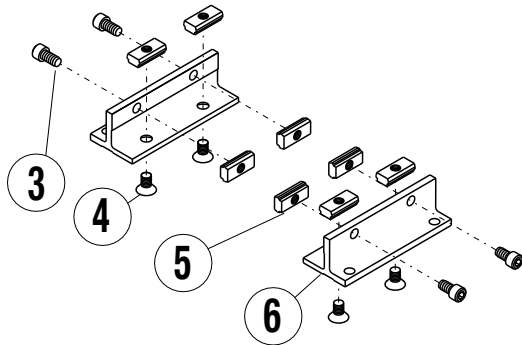

**MOUNTING PLATES**

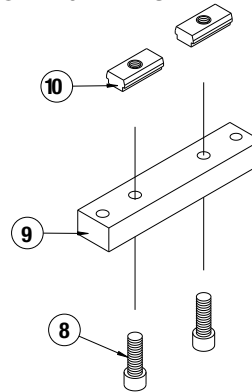

ITEM	US CONV (SK)	METRIC (SM)	DESCRIPTION	QTY
<b>TUBE SUPPORT KIT</b>				
3.	2317-1015	4415-1011	SIDE FASTENER	4
4.	3415-1046	4415-1014	BOTTOM FASTENER	4
5.	3420-1013	4420-1013	T-NUT	4
6.	3420-1044	3420-1044	TUBE SUPPORT	2
<b>MOUNTING PLATES</b>				
8.	2307-1018		FASTENER	2
		4415-1018	FASTENER	2
9.	3420-1232	3420-1232	MOUNTING PLATE, B3W, 0.50	1
10.	3420-1013	4420-1013	T-NUT	2

**OPTIONAL ACCESSORY ASSEMBLY INSTRUCTIONS**

1. **TUBE SUPPORTS.** Four T-Nuts (5) are required on each side of the Tube (30), two T-Nuts on bottom of Tube and two in lower slots on tube sides. Tube Supports should be secured at the required distances determined for the application to prevent Tube deflection. Apply Loctite #242 to Screws (4) and secure Tube Supports (6) to Tube aligning holes in T-Nuts with holes in Tube Supports.

**WIRING DIAGRAMS**

**R T & R M DC REED, FORM A**

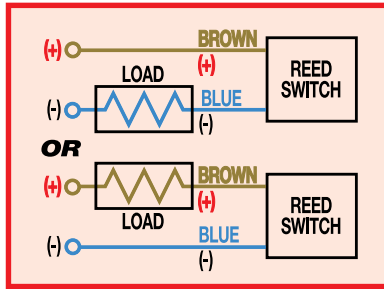

**C T & C M AC REED, TRIAC**

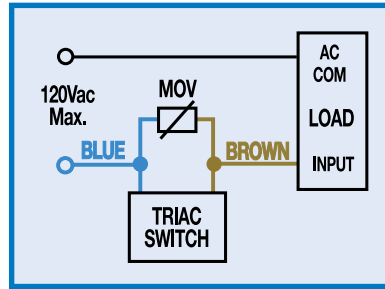

**B T & B M DC REED, FORM C**

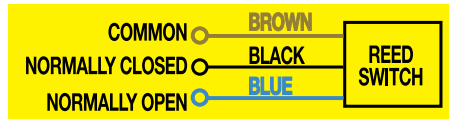

Some actuators may require switch mounting on a specific side of the assembly. Call Tolomatic for details.

**T T & T M HALL-EFFECT, SOURCING, PNP**

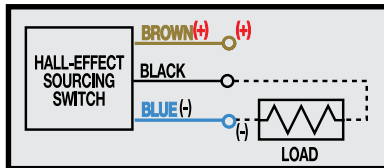

**K T & K M HALL-EFFECT, SINKING, NPN**

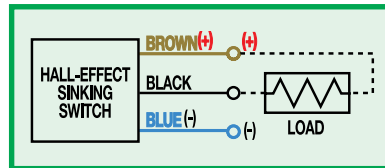

**INSTALLATION INFORMATION**

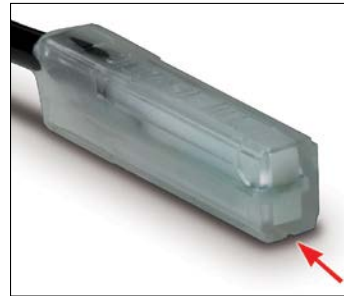

**⚠**  
THE NOTCHED FACE OF THE SWITCH INDICATES THE SENSING SURFACE AND MUST FACE TOWARD THE MAGNET.

**REPLACEMENT OF QD SWITCHES MANUFACTURED BEFORE JULY 1, 1997:**

It will be necessary to replace or rewire the female end coupler.



**Female Connector 5M**

Loctite® is a registered trademark of the Loctite Corporation, www.loctite.com  
Mobil grease® HP is a registered trademark of Mobil Oil Corporation, www.mobil.com



3800 County Road 116, Hamel, MN 55340 USA  
http://www.Tolomatic.com • Email: Help@Tolomatic.com  
Phone: (763) 478-8000 • Fax: (763) 478-8080 • Toll Free: 1-800-328-2174

COMPANY WITH  
QUALITY SYSTEM  
CERTIFIED BY DNV GL  
= ISO 9001 =

All brand and product names are trademarks or registered trademarks of their respective owners. Information in this document is believed accurate at time of printing. However, Tolomatic assumes no responsibility for its use or for any errors that may appear in this document. Tolomatic reserves the right to change the design or operation of the equipment described herein and any associated motion products without notice. Information in this document is subject to change without notice.