

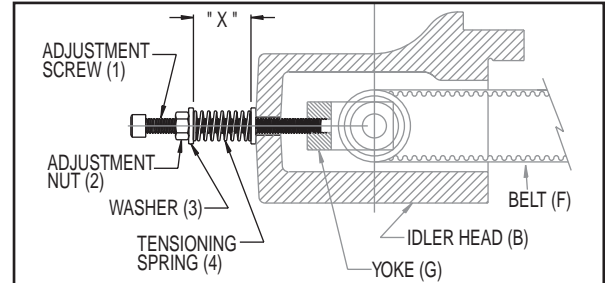

Axidyne® Belt-Tension Kit

3410-0819 & 3415-0838

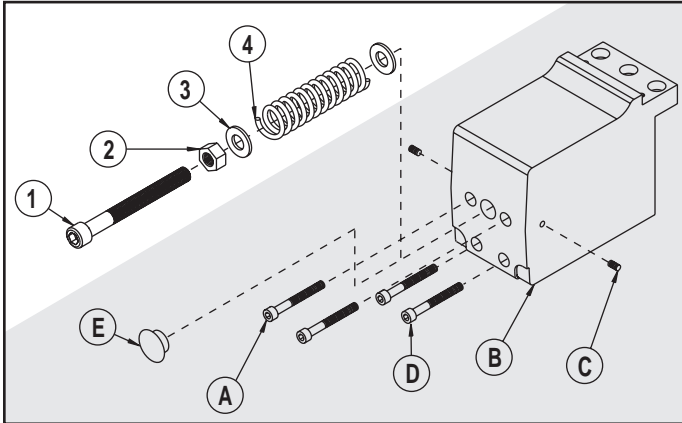

ADJUSTING BELT TENSION USING THE BELT TENSION KIT

To adjust belt tension using the Belt Tension Kit, follow these instructions.

* NOTE: Kits include items 1-4 only. Parts are not sold individually. Grey items are not included in these kits. These products should be on existing drives.

List of Parts

Item	Part No.	Description	B3B10	B3B15	B3B20
	34159253	B3B kit (items 1-4)		x	
1	34101091	Adjustment Screw			
	34152008	Adjustment Screw	1		
	24201503	Adjustment Screw			
2	7011059	Adjustment Nut			
	30001009	Adjustment Nut	1		
3	77201007	Washer			
	24101135	Washer	2		
4	34101092	Spring			
	34152007	Spring	1		
A.	1408-3412	SHCS, #10-24 x 1.50			
	4910-1061	SHCS, M5 x 0.8 x 40mm			
B.	3420-1401	Head Idler, B3B20			
	4420-1401	Head Idler, M3B20			
C.	0905-1077	Set Screw, #6-32 x .50, cone			
	0610-1046	Set Screw, M4 x 0.7 x6mm			
D.	6000-1473	SHCS, #10-24 x 1.38			
	4910-1061	SHCS, M5 x 0.8 x 40mm			
E.	3420-1431	Button Plug			
F.	3420-1421	Belt, 5mm pitch, 1.25" wide, neoprene			
G.	3420-1411	Yoke, B3B20			
	4420-1411	Yoke, M3B20			

- Remove the band clamp from the idler head and roll the band backwards so that the drive belt can be observed while tensioning the belt. Remove the Cap Plug (E).
- Attach Belt Tension Kit
 - Thread the adjusting nut (2) onto the adjusting screw (1) all the way to the end of the threads on the adjusting screw.
 - Place the washer (3), spring (4), and second washer (3) onto the adjusting screw (1).
 - Insert the adjusting screw into the idler housing (B) and thread the adjusting screw (1) into the yoke about 4 turns.
* Caution: Threading adjustment screw in too far may cause belt damage.
- Apply Tension To The Belt
 - While holding the adjusting screw (1) so that it doesn't turn-turn adjusting nut (2) until dimension "X" between the inside of the 2 washers is achieved. (Dim. "X" is shown in the adjustment table below.)
- Lock Yoke Into Position
 - Insert one yoke positioning socket head cap screw (A) thru the rear of the idler head (B) and thread into the yoke (G). While viewing the belt thru the top opening, near the idler head, turn the screw into the yoke slowly until the belt (F) moves just slightly to the side. Repeat the process for the second yoke positioning screw.
 - Screw the 2 set screws (C) into the side of the idler head (B) to lock the yoke (G), positioning the screws into place. The belt is now properly tensioned. Remove the belt tension kit and insert the cap plug (E) into the back of the idler head.

ADJUSTMENT TABLE	
"X" Dimension (inches)	
3410-0819.....	1.70
3415-0838.....	1.70



TOL-O-MATIC, INC.

3800 County Road 116, Hamel, MN 55340
http://www.Tolomatic.com • Email: Help@Tolomatic.com
Phone: (763) 478-8000 • Fax: (763) 478-8080 • Toll Free: 1-800-328-2174



Information furnished is believed to be accurate and reliable. However, Tol-O-Matic assumes no responsibility for its use or for any errors that may appear in this document. Tol-O-Matic reserves the right to change the design or operation of the equipment described herein and any associated motion products without notice. Information in this document is subject to change without notice.