

### MXE63S Solid Bearing Screw-Drive Actuators

#### 63mm (2-1/2 inch) Series

Models: BN01      BN02  
           BN04      SN04

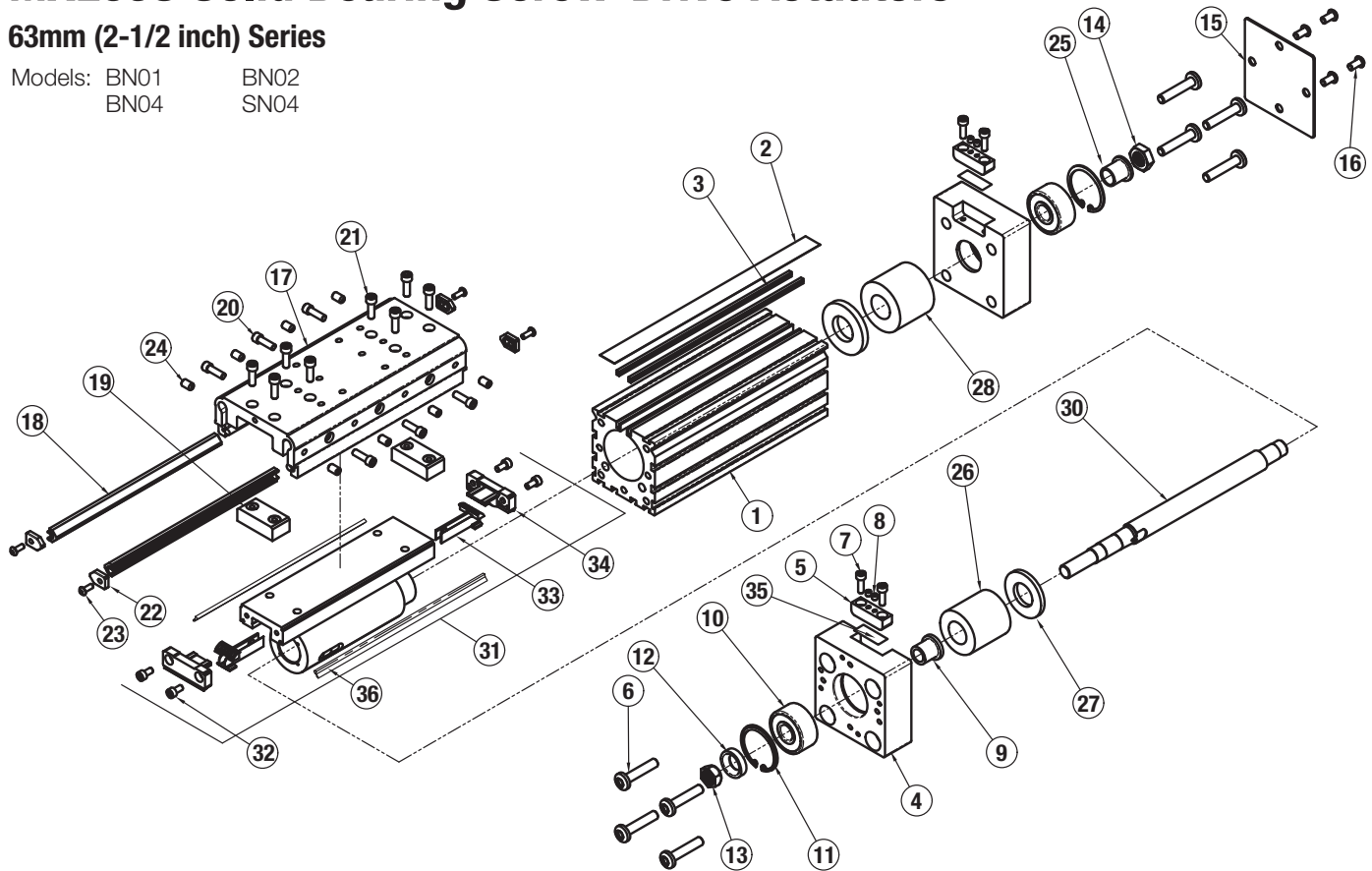

ITEM	PART NO. OR CONFIG. CODE	DESCRIPTION	MXE63S			
			BN01	BN02	BN04	SN04
2 <sup>1</sup>	RTBMXE63_SK_	TUBE (US CONV)	1	1	1	1
	RTBMXE63_SM_	TUBE (METRIC)	1	1	1	1
1,3,2	NDBMXE63_SK_	DUST BAND (US CONV)	1	1	1	1
	NDBMXE63_SM_	DUST BAND (METRIC)	1	1	1	1
3,3	NMBMXE63_SK_	MAGNET BAND KIT (US CONV)	2	2	2	2
	NMBMXE63_SM_	MAGNET BAND KIT (METRIC)	2	2	2	2
4.	8363-1011	MACHINED HEAD	2	2	2	2
5.	8363-1017	BAND CLAMP	2	2	2	2
6.	8350-1023	PAN HEAD SCREW	8	8	8	8
7.	2212-1031	SOCKET HEAD CAP SCREW	4	4	4	4
8.	8140-1073	SET SCREW	4	4	4	4

ITEM	PART NO. OR CONFIG. CODE	DESCRIPTION	MXE63S			
			BN01	BN02	BN04	SN04
9.	1150-1144	LEADSCREW SLEEVE	2	2	2	2
10.	2133-1022	BEARING	2	2	2	2
11.	2133-1021	RETAINING RING	2	2	2	2
12.	1150-1114	SPHERICAL WASHER	1	1	1	1
13.	1150-1113	SPHERICAL NUT	1	1	1	1
14.	2124-1023	JAM HEX NUT	1	1	1	1
15.	8363-1022	END CAP	1	1	1	1
16.	8340-1009	BUTTON HEAD CAP SCREW	4	4	4	4
	8363-1513	CARRIER (US CONV)	1	1	1	1
17.	8363-1013	CARRIER (METRIC)	1	1	1	1
	8163-1030	SOLID BEARING	2	2	2	2

<sup>1</sup> Parts included in Repair Kits. (RKMXE63S\_SK\_ or RKMXE63S\_SM\_, indicate stroke length in inches or millimeters)

Note: Shaded areas denote discontinued models

<sup>2</sup> Replacement Tube ordering method: **RTB** MXE63S SK DC  
**EXAMPLE:** **RTB** MXE63S BN02 SK 21.25 DC7

<sup>3</sup> Replacement ordering method: MXE63S SK DC  
**EXAMPLE:** NDB MXE63S SK 21.25 DC7

Magnet Band (NMB) or Dust Band (NDB)      Model & Size      Bearing      Stroke Length      Aux. Carrier

**Auxiliary Carrier Option Note:** If replacing a Tube (1.) or Dust Band (2.), Magnet Band Kit (3.) or Lead Screw (30.) on an actuator that has an Auxiliary Carrier, be sure to add "DC \_\_\_" to the end of the configuration string when ordering. "DC" indicates the need for additional length and "\_\_\_" indicates the measurement of space between carriers (in inches [SK] or millimeters [SM] as indicated earlier in the configuration string).

Drawing repeated for reference

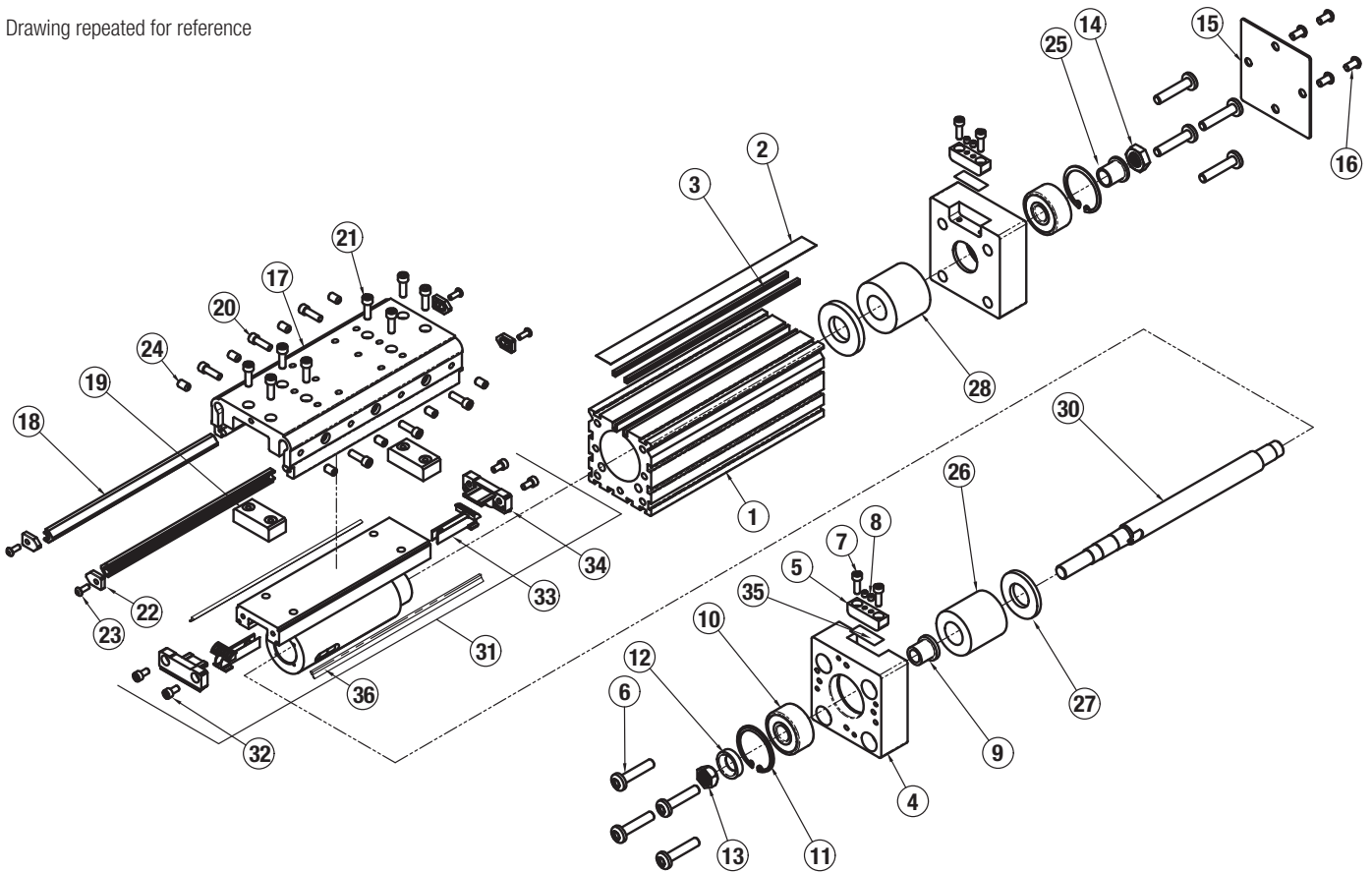

ITEM	PART NO. OR CONFIG. CODE	DESCRIPTION	MXE63S			
			BN01	BN02	BN04	SN04
19.	8163-1025	CARRIER SPACER BLOCK	2	2	2	2
20.	1009-1065	TENSION SCREW (US CONV)	6	6	6	6
	8163-1071	TENSION SCREW (METRIC)	6	6	6	6
21.	2164-1065	SOCKET HEAD CAP SCREW	8	8	8	8
22.	8163-1031	BEARING END CAP	4	4	4	4
	8340-1009	BUTTON HEAD CAP SCREW	4	4	4	4
24.	8163-1572	SET SCREW (US CONV)	8	8	8	8
	8163-1072	SET SCREW (METRIC)	8	8	8	8
25.	8363-1027	FLANGED SLEEVE BEARING	1	1	1	1
26.	8363-1024	NYLON SPACER	1	8	8	8
27.	8363-1023	BUMPER	2	4	4	4
28.	8363-1025	NYLON SPACER	1	1	1	1
30.	RLSMXE63_SK	LEADSCREW (US CONV)	A/R	A/R	A/R	A/R
	RLSMXE63_SM	LEADSCREW (METRIC)	A/R	A/R	A/R	A/R

ITEM	PART NO. OR CONFIG. CODE	DESCRIPTION	MXE63S			
			BN01	BN02	BN04	SN04
31.	8363-9006	NUT BRACKET ASSEMBLY, BN01	1	-	-	-
	8363-9007	NUT BRACKET ASSEMBLY, BN02	-	1	-	-
	8363-9008	NUT BRACKET ASSEMBLY, BN04	-	-	1	-
	8363-9009	NUT BRACKET ASSEMBLY, SN04	-	-	-	1
32.	0603-1016	SOCKET HEAD CAP SCREW, SS	4	4	4	4
1,2,3	8363-1007	BAND RAMP	2	2	2	2
1,2,3	8163-1006	END CAP	2	2	2	2
35.	8325-1055	SHIM	2	2	2	2
	8325-1056	SHIM	2	2	2	2
	8325-1057	SHIM	2	2	2	2
1,3	8163-1059	WIPER	2	2	2	2

<sup>1</sup> Parts included in Repair Kits. (RKMXE63S\_SK\_ or RKMXE63S\_SM\_, indicate stroke length in inches or millimeters)

<sup>2</sup> Parts included in Nut Bracket Assembly

<sup>3</sup> Replacement Lead Screw ordering method: **RLS** **MXE63S** **S** **BN02** **SK21.25** **LMIYM** **0TBD0** **DC7**

Lead Screw — Model & Size — Bearing — Nut Style & Size — Stroke Length — Motor Orientation — Motor Code — Aux. Carrier

Auxiliary Carrier Option Note: If replacing a Tube (1.) or Dust Band (2.), Magnet Band Kit (3.) or Lead Screw (30.) on an actuator that has an Auxiliary Carrier, be sure to add "DC \_\_\_" to the end of the configuration string when ordering. "DC" indicates the need for additional length and "\_\_\_" indicates the measurement of space between carriers (in inches [SK] or millimeters [SM] as indicated earlier in the configuration string).

## Assembly and Disassembly Instructions

Drawing repeated for reference

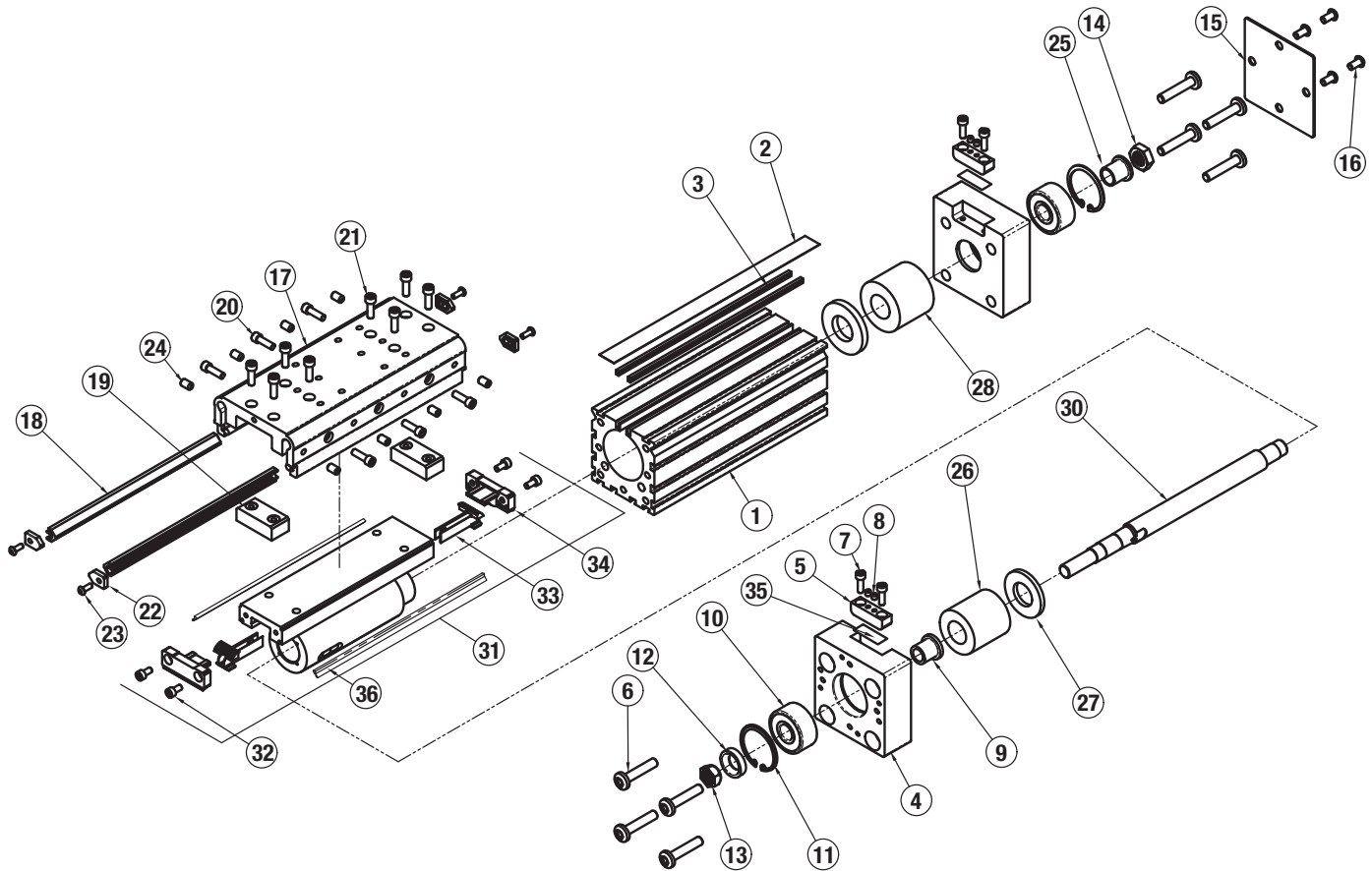

### GENERAL ACTUATOR DISASSEMBLY INSTRUCTIONS

Begin with a clean work area. Be sure all replacement parts are present and have no visual damage or defects. The following tools are recommended for proper disassembly and assembly.

- SAE Hex Wrench Set
- Metric Hex Wrench Set
- Torx bit set
- Metric Socket Set
- SAE Socket Set

For best actuator performance it is recommended that the following instructions be read and followed carefully.

#### 1. Dust Band and Carrier Removal

Remove the Band Clamps (5) from both Heads (4) of the actuator by removing Screws (7) and backing out the Center Set Screws (8) a couple turns. Carefully lift the Dust Band (2) from the slot in each Head (4) and remove any Shims (35) located under the Band (2) in the Head (4) slot. Retain the Shims (35) for reassembly. Remove the Carrier Spacer Blocks (19). Remove Screws (21) from the Carrier (17). Remove End Caps (34) from both ends of the Nut Bracket Assembly (31). The Dust Band (2) can now be removed from the actuator. Slightly loosen the Carrier Tension Screws (20) and Lock (Set) Screws (24). Remove Bearing End Caps (22) from the Solid Bearings (18) and slide the Solid Bearings (18) out. The Carrier (17) can now be removed.

**NOTE:** If the stroke of the actuator is too short to allow removal of the Solid Bearings (18), it is necessary to remove the *Non-Drive End Head* (4) from the Tube (1).

#### 2. Leadscrew Sub-Assembly Removal

On the *Non-Drive End* of the actuator, remove Screws (16) to remove the Cover Plate (15), and Hex Nut (14) from the Leadscrew (30). Remove Screws (6) from both Heads (4). Remove the *Non-Drive End Head* and the Drive Head/Leadscrew Assembly (30). The Nut Bracket Assembly (31) can now be removed from the Leadscrew (30) if necessary and the Band Ramps (33) may also be removed from the Nut Bracket Assembly (31) if required.

**Ball Nut style:** Caution is required if removal of the nut is necessary. Contact the factory for available parts and procedures.

**Plastic Nut style:** Plastic Nuts are factory pinned into the Nut Bracket and cannot be removed. If Nuts are worn, a new Nut Bracket Assembly (31) must be ordered.

If the *Drive End Head* (4) and Bearing (10) must be removed from the Leadscrew (30), contact the factory prior to removal for specific instructions.

**GENERAL ACTUATOR ASSEMBLY INSTRUCTIONS****1. Sub-Assembly Carrier**

Slide the Solid Bearings (18) into the slots on the Carrier (17) and install Bearing End Caps (22) loosely onto the Bearing Ends with Screws (23). Keep the Tension Screws (20) and Lock (Set) Screws (24) loose. If removed, install the Band Ramps (33) to the Nut Bracket Assembly (31).

**2. Install Leadscrew Assembly**

Install the Drive Head/Leadscrew Assembly (30) into the Tube (1). Ensure that the Bumper (27) and Nut Spacer (26) are in place and position the Non-Drive End Head (4) over the Leadscrew (30) and loosely install Screws (6) into the Head (4). Install the Screws (6) loosely into the *Drive End* Head (4).

**3. Install Dust Band**

Install the Dust Band (2) through the Nut Bracket Assembly (31) and install End Caps (34) onto the Nut Bracket Assembly (31). Position Carrier (17) sub-assembly onto the Tube (1).

**4. Tension the Carrier**

The MX Solid Bearing Carrier (17) will provide best performance when properly adjusted. The carrier design contains both Tension (20) and Lock Screws (24). The Tension Screws (20) control the amount of pressure placed on the Solid Bearings (18). The Lock Screws (24) lock the Tension Screws (20) in place and provide fine adjustment of the Solid Bearings (18).

**Tools Required:****Inch Models:**

3/16 and 5/32 inch Hex Key

**Metric Models:**

4 and 2.5 mm Hex Key

- Fully loosen all Tension (20) and Lock Screws (24) about 1/2 of a turn so that they are not engaged with the Solid Bearing (18).
- Tighten Tension Screws (20) on both sides of the Carrier (17) roughly 1/8 to 1/4 turn clockwise past where the Screw (20) starts to feel snug. The Carrier (17) should be very difficult or impossible to move by hand. If not, tighten another 1/8 turn until it is difficult to move.
- Next, adjust the Lock Screws (24) on both sides of the Carrier (17) roughly 1/8 to 1/4 turn clockwise past where the Screw (24) starts to engage. The Carrier (17) will be loose but should not rock sideways. To correct this, loosen the Lock Screws (24) about 1/16 of a turn. If the Carrier (17) becomes too

- snug, tighten the Lock Screws (24) another 1/8 of a turn.
- Ideal carrier tension is achieved when the Carrier (17) feels snug in relation to the Tube (1), yet can be moved by hand. No rocking motion should be present. The Carrier (17) should also be loose enough to be moved by hand over the entire length of the actuator. If after this process the Carrier (17) has become too loose, equally adjust all of the Lock Screws (24) with a slight 1/32 turn counter-clockwise.

**During the service life of the application this process may need to be repeated. Keeping the Carrier (17) in a properly adjusted tension will prolong the life of the MX bearing system and the actuator itself.**

- When the proper carrier tension has been achieved, finish tightening the four Screws (23) to the Bearing End Caps (22).
- Position the Carrier (17) over the Nut Bracket Assembly (31) and install Screws (21). Install the Carrier Spacer Blocks (19) to the Carrier (17).

**5. Perform Head Alignment And Final Assembly.**

NOTE: Custom tooling is used at the factory to align the Heads (4) to the Tube (1) to maintain parallelism between the top of the Head (4) and top of the Tube (1). In the following steps take care to visually align Head (4) to Tube (1).

Move the assembled Carrier (17) to the *Drive End* of Tube (1) and tighten one of the Head Screws (6), supporting the actuator so the Head (4) is free to float while tightening the Screws (6). Move the Carrier (17) Assembly to *Non-Drive End* of Tube (1) and tighten the Head Screws (6). Move Carrier Assembly (17) back to the Drive End of Tube (1) and loosen the Screw (6) that was previously tightened and then tighten all Head Screws (6). Apply Loctite 242 to Hex Nut (14) and thread onto the Leadscrew (30) and torque to 18-20 in-lbs (2-2.25 N-m). Install Cover Plate (15) with Screws (16).

**6. Install Band Clamps**

The Dust Band (2), Tube (1) and clamping surface of the Head (4) must be flush with each other. To accommodate this, it may be necessary to re-install any Shims (35) that were present during disassembly into the clamp pocket on the Head (4). Position the Carrier (17) near the Drive End and position the Dust Band (2) in the Head (4) pocket over the installed Shims (35) and install the Band Clamp (5) with the two Screws (7). Tighten down the Center Set Screws (8). Position the carrier near the *Non-Drive End* and repeat the steps to install the other Band Clamp (5).

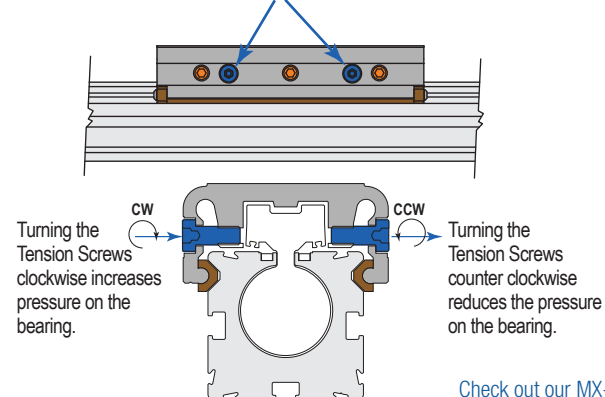
**TENSION SCREWS**

Check out our MX--S carrier adjustment video on the web  
<https://youtu.be/LVWPg2qfy0A>

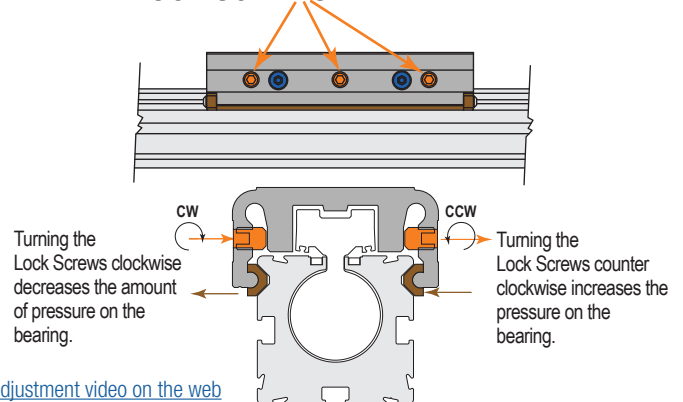
**LOCK SCREWS**

## Reverse Parallel (RP) Mounting Option

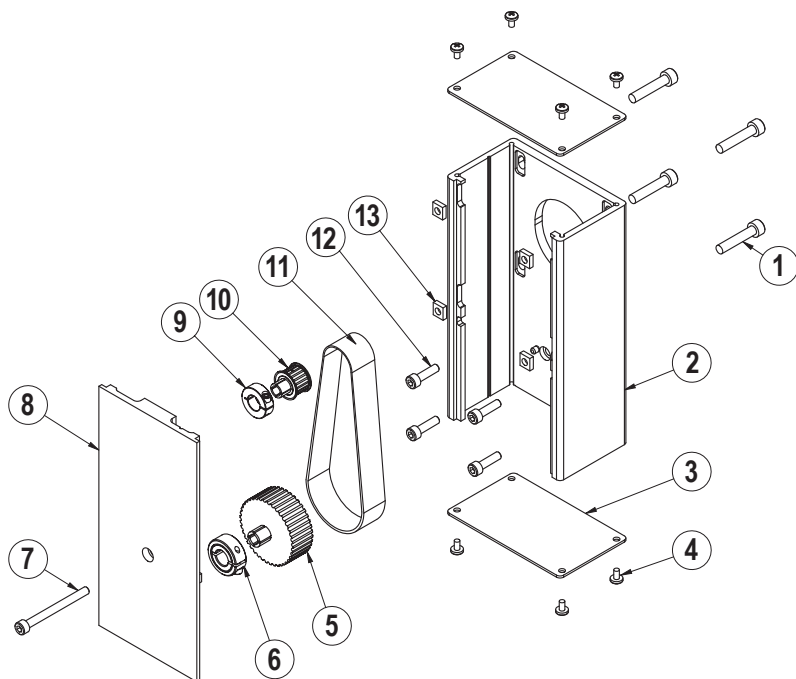

ITEM	PART NO.	DESCRIPTION	QTY.
◊1.	CONFIGURED	MOTOR FASTENER	4
◊2.	CONFIGURED	RP HOUSING	1
◊3.	CONFIGURED	RP HOUSING END CAP	2
◊4.	CONFIGURED	END CAP SCREW	8
◊5.	CONFIGURED	DRIVE SHAFT PULLEY	1
◊6.	CONFIGURED	COLLAR CLAMP, DRIVE SHAFT	1
◊7.	CONFIGURED	RP COVER FASTENER	1
◊8.	CONFIGURED	RP COVER	1
◊9.	CONFIGURED	COLLAR CLAMP, MOTOR	1
◊10.	CONFIGURED	MOTOR PULLEY	1
◊11.	CONFIGURED	BELT	1
◊12.	CONFIGURED	RP PLATE FASTENER	4
◊13.	CONFIGURED	SQUARE NUT	4

◊ Part numbers varies depending on YMH (Your Motor Here).  
Contact [help@tolomatic.com](mailto:help@tolomatic.com) for replacement part numbers.

### Disassembly Instructions

1. Remove End Caps (3), and release the tension on the Belt (11) by breaking loose the motor fasteners (1).
2. Remove the RP Cover (8).
3. The Belt (11) can now be removed along with the Motor.
4. Remove both Pulleys (10) and (5) from their respective shafts.
5. Remove the RP Housing (2) from the actuator head by removing the Fasteners (12).

### Assembly Instructions

Note: Apply Loctite #242 to all fasteners upon installation

1. Install RP Housing (2) onto the actuator Head with Fasteners (12).  
**Note:** If the RP housing has a bearing in it do not fully tighten the fasteners at this time. Instead temporarily install the RP cover (8) onto the RP case, positioning the bearing over the leadscrew shaft. Hold the cover in place while tightening all the Fasteners (12) so that the case is snug. Then remove the RP cover and finish tightening the fasteners
2. Install the Motor to the RP Housing with Fasteners (1) and Square Nuts (13). Do not tighten the fasteners at this time.
3. Locate the Belt (11) over the Pulleys (10) and (5) and slide both pulleys over their respective shafts. Tighten each pulley to its shaft with the Collar Clamps (9) and (6).

4. Tension the Belt (11) by pulling the motor away from the drive shaft with the appropriate tension force shown in the chart below. While tensioning, the actuator should be positioned so the weight of the motor does not affect the belt tension. Tighten the Motor Fasteners (1) while the tensioning force is applied to the motor.

SMALLEST SHAFT DIAMETER (Motor or Actuator)		TOTAL WEIGHT TO APPLY	
Inches	mm	lbs	kgs
0.18 to 0.259	4.572 to 6.579	13	5.902
0.260 to 0.499	6.604 to 12.675	22	9.988
0.500 to 0.625	12.7 to 15.875	31	14.074
0.625 and larger	15.875 and larger	40	18.160

Additional tips are found in Tolomatic [Electric Actuator Motor Mounts Technical Note # 3600-4203](#).

5. Verify that there is clearance between the inside of the RP case and each pulley. Verify the pulleys are aligned to each other.
6. Position the Cover (8) in the mating slot of the RP case and install the Fasteners (7) to hold it in place. Take care not to overtighten. If the cover is deflected, it can interfere with the leadscrew.
7. Install both End Caps (3) with the Screws (4) to finalize the assembly.



### Actuator Options

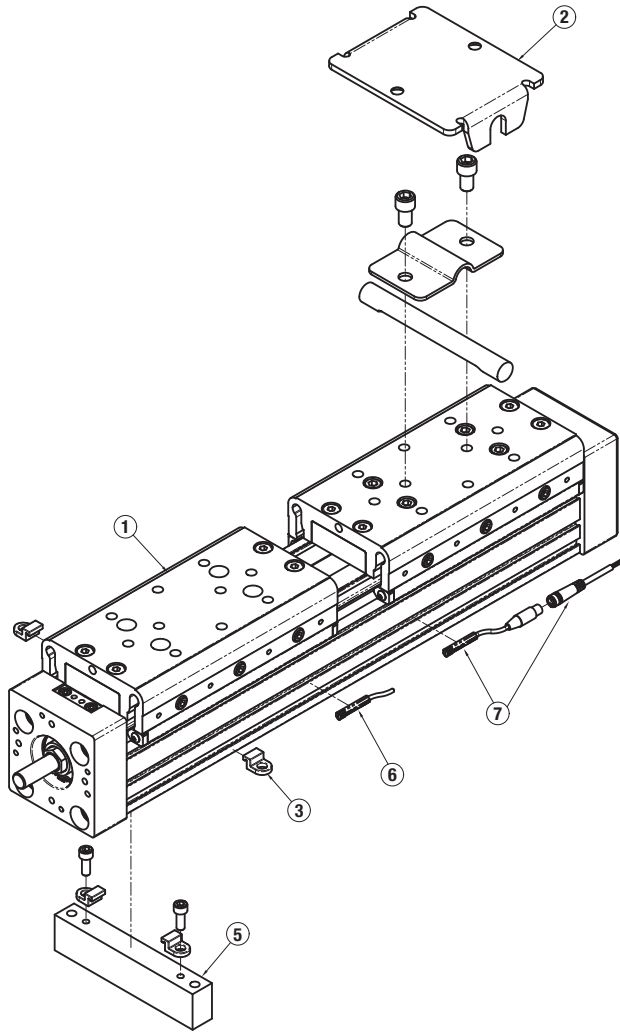

ITEM	PART NO.	DESCRIPTION	QTY IN KIT
1.	8363-9515	AUXILIARY CARRIER ASSEMBLY, (INCH)	
	8363-9015	AUXILIARY CARRIER ASSEMBLY, (METRIC)	
2.	8163-9536	<b>FLOATING MOUNT KIT (INCH)</b>	
	8163-9036	<b>FLOATING MOUNT KIT (METRIC)</b>	
	0925-1054	FLOATING MOUNT CLAMP	1
	8163-1068	FLOATING MOUNT BRACKET	1
	8163-1069	PIN	1
	8163-1570	SOCKET HEAD CAP SCREW (INCH)	4
	8150-1074	SOCKET HEAD CAP SCREW (METRIC)	4
3.	8163-9018	<b>TUBE CLIP MOUNT KIT</b>	
	8163-1050	TUBE CLAMP	2
5.	8363-9016	<b>MOUNTING PLATE KIT</b>	
	8363-1031	MOUNTING PLATE	1
	8163-1050	TUBE CLAMP	2
	8363-1044	BUTTON HEAD CAP SCREW	2

**To order service parts switches:**

Switches for MXE include retained mounting hardware and are the same for all actuator sizes and bearing styles

ITEM	CONFIG. CODE	LEAD	NOR-MALLY	SENSOR TYPE
4.	SWMXE63S <b>R</b> <b>Y</b>	5M (197 IN)	OPEN	REED
5.	SWMXE63S <b>R</b> <b>K</b>	QUICK-DISCONNECT		
4.	SWMXE63S <b>N</b> <b>Y</b>	5M (197 IN)	CLOSED	REED
5.	SWMXE63S <b>N</b> <b>K</b>	QUICK-DISCONNECT		
4.	SWMXE63S <b>T</b> <b>Y</b>	5M (197 IN)	OPEN	SOLID STATE PNP
5.	SWMXE63S <b>T</b> <b>K</b>	QUICK-DISCONNECT		
4.	SWMXE63S <b>K</b> <b>Y</b>	5M (197 IN)	OPEN	SOLID STATE NPN
5.	SWMXE63S <b>K</b> <b>K</b>	QUICK-DISCONNECT		
4.	SWMXE63S <b>P</b> <b>Y</b>	5M (197 IN)	CLOSED	SOLID STATE PNP
5.	SWMXE63S <b>P</b> <b>K</b>	QUICK-DISCONNECT		
4.	SWMXE63S <b>H</b> <b>Y</b>	5M (197 IN)	CLOSED	SOLID STATE NPN
5.	SWMXE63S <b>H</b> <b>K</b>	QUICK-DISCONNECT		

MATING QD CABLE IS INCLUDED.

### Ordering Repair Kits

Repair kit includes: dust band, end caps, wipers, solid bearings, bearing end caps

The part number for a repair kit begins with RK followed by model, actuator size, bearing type, and stroke length (**SIK** = inch/US Standard, **SM** = metric)

(NOTE: If unit has an auxiliary carrier also include DC and distance between carrier centers)

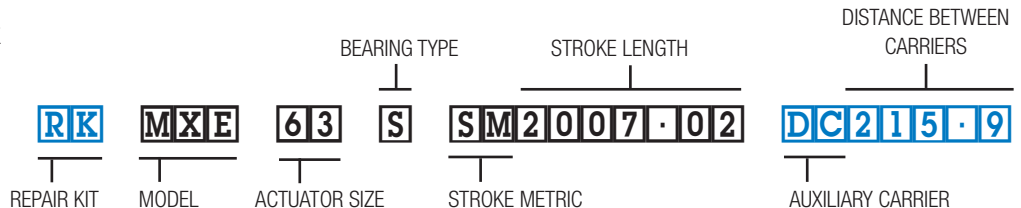

**Switch Wiring Diagrams and Label Color Coding (Ce and Rohs Compliant)**

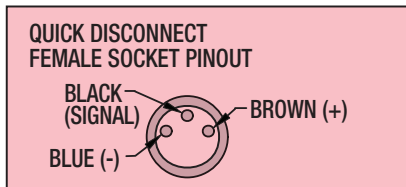
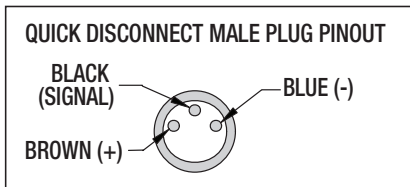
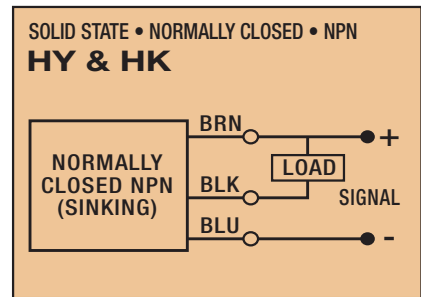
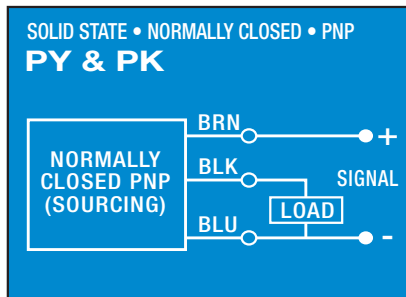
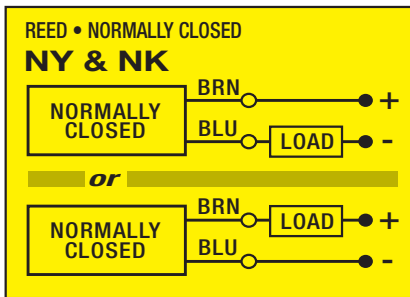
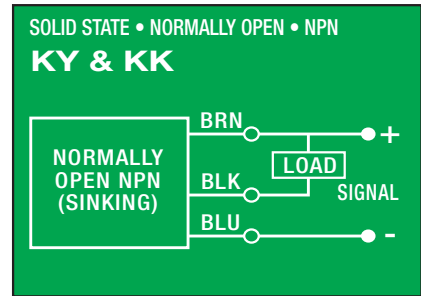
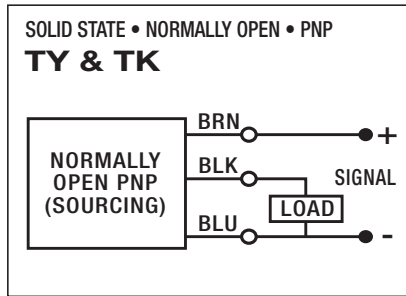
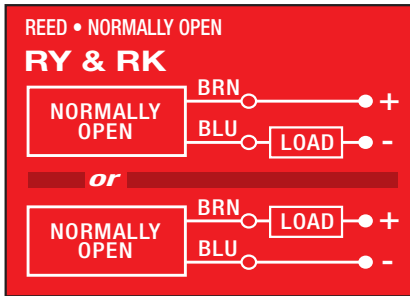

Switches for MX:

- Include retained mounting hardware
- In slot, sit below extrusion profile
- Same for all sizes and bearing styles

**Switch installation and replacement**

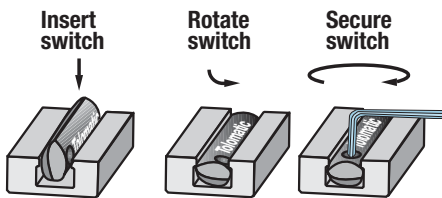

Place switch in side groove on tube at desired location with "Tolomatic" facing outward. While applying light pressure to the switch, rotate it such that the switch is halfway in the groove. Maintaining light pressure, rotate the switch in the opposite direction until the switch is fully inside the groove with "Tolomatic" visible. Re-position the switch to the exact location and lock the switch securely into place by tightening the screw on the switch.

**Switch Detection point**

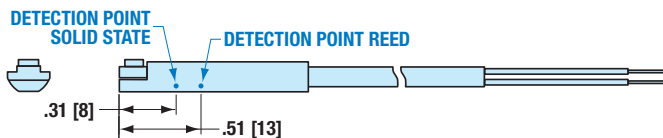

Dimensions in inches [brackets indicate dimensions in millimeters]



3800 County Road 116, Hamel, MN 55340 USA  
 http://www.Tolomatic.com • Email: Help@Tolomatic.com  
 Phone: (763) 478-8000 • Fax: (763) 478-8080 • Toll Free: 1-800-328-2174

COMPANY WITH  
 QUALITY SYSTEM  
 CERTIFIED BY DNV GL  
 = ISO 9001 =

All brand and product names are trademarks or registered trademarks of their respective owners. Information in this document is believed accurate at time of printing. However, Tolomatic assumes no responsibility for its use or for any errors that may appear in this document. Tolomatic reserves the right to change the design or operation of the equipment described herein and any associated motion products without notice. Information in this document is subject to change without notice.